



CMS32M55xx Datasheet

ARM® Cortex® -M0 32-bit motor microcontroller

Rev. 1.2.1

Please note the following CMS IP policy

* China Micro Semicon (Shenzhen) Co., Ltd. (hereinafter referred to as the Company) has applied for a patent and enjoys absolute legal rights and interests. The patent rights related to the Company's MCUs or other products have not been authorized to be licensed, and any company, organization or individual who infringes the Company's patent rights through improper means will take all possible legal actions to curb the infringer's improper infringement and recover the losses suffered by the Company as a result of the infringement or the illegal benefits obtained by the infringer.

* The name and logo of China Micro Semicon (Shenzhen) Co., Ltd. are registered trademarks of the Company.

* The Company reserves the right to further explain the reliability, functionality and design improvements of the products in the data sheet. However, the Company is not responsible for the use of the Specification Contents. The applications mentioned herein are for illustrative purposes only and the Company does not warrant and does not represent that these applications can be applied without further modification, nor does it recommend that its products be used in places that may cause harm to persons due to malfunction or other reasons. The Company's products are not licensed for lifesaving, life-sustaining devices or systems as critical devices. The Company reserves the right to modify the product without prior notice, please refer to the official website www.mcu.com.cn for the latest information.

1. Product Features

1.1 MCU Functions

- ◆ **Built in ARM Cortex™-M0, 64MHz@2.1V~5.5V**
 - Single periodic 32-bit hardware multiplier
- ◆ **32-bit hardware divider (HWDIV)**
 - Signed/unsigned mode, 6 HCLK to complete calculation
- ◆ **Memory**
 - Maximum 32K byte program FLASH (APROM + BOOT)
 - 1K byte FLASH data space (separated space)
 - Maximum 8K byte SRAM (support distributed write-protection)
 - Support BOOT function, BOOT unit can be set from 0-4K
 - Support hardware CRC verification FLASH spatial encoding
 - Support FLASH partition protection (min. unit of 2K)
- ◆ **System clock**
 - High speed internal clock: 48MHz/64MHz (HSI)
 - Low speed internal clock: 40KHz (LSI)
- ◆ **GPIO (max. 24 I/Os)**
- ◆ **LVR(1.9V/2.1V/2.6V)**
- ◆ **LVD(2.0V/2.2V/2.4V/2.7V/3.0V/3.7V)**
- ◆ **System timer**
 - 24-bit SysTick timer
 - Watchdog timer (WDT)
 - Windowed watchdog timer (WWDT)
- ◆ **Normal/sleep/deep sleep mode**
- ◆ **Cyclic Redundancy Check (CRC)**
- ◆ **Timer(32bit/16bit-TIMER0/1)**
- ◆ **Capture, Compare and PWM(CCP0/1)**
 - Support 4-channel concurrent capture, can connect to Hall-effect sensor interface
- ◆ **Communication interface**
 - 1 I²C module (max. speed of 1Mb/s)
 - 1 SSP/SPI module (4 to 16-bit data format adjustable)
 - Max. 2 UART : UART0/1 (total 32 receive/transmit FIFO) (TXD1 and RXD1 of UART1 can be set to any interfaces)
- ◆ **Serial Wire Debug (2 Wire)**
- ◆ **96-bit unique ID (UID)**
- ◆ **128-bit user UID (USRUID)**
 - User can set and encrypt (can be use as security key)
- ◆ **Enhanced PWM (EPWM)**
 - 6 channels and channels can remap
 - Support individual/complementary/synchronized/grouped output mode
 - Support edge/center aligned mode
 - Support single/continuous/interval update mode
 - Support complementary pwm with dead-time insertion
 - Support mask and pre-set mask (total of 8 mask state cache)
 - Support Hall-effect sensor port (hardware controls PWM output)
 - Support hardware brake and 6 sources of brake signal
- ◆ **ADC0(12bit, 100Ksps)**
 - Max. 24 input channels
 - Each converting channel has separated product registers
 - Support single/continuous mode
 - Support 2 hardware triggers with 7 sources of trigger
 - 1 converted output comparator, can generate interrupt
- ◆ **ADC1(12-bit, 1.2Msps)**
 - Max. 24 input channels
 - Each converting channel has separated product registers
 - Support single/continuous/inserting mode
 - Support external trigger mode
 - 1 converted output comparator, can generate interrupt
- ◆ **Analog comparator (ACMP0/1)**
 - 4 choices from positive end, negative end can choose internal 1.2V/VDD
 - Support hysteresis voltage choice : 10mV/20mV/60mV
 - Support comparator output triggered EPWM brake
- ◆ **Programmable gain amplifier (PGA0/1)**
 - 4 choices in positive end
 - Output can connect to internal ADC channel and the input of analog comparator
 - Internal gain of : 4~32
- ◆ **Operational amplifier (OP0/1)**
 - Input can connect to internal 1.2V
 - Output can connect to internal ADC channel and the input of analog comparator
 - Can set to comparator mode
- ◆ **Support security-related applications and functions**
 - Satisfy IEC60730 CLASS B

1.2 Product Comparison

Product		CMS32M5510	CMS32M5512	CMS32M5524	CMS32M5526	CMS32M5526C	CMS32M5533	CMS32M5533E	CMS32M5536	
Peripherals										
Supply power of built-in driver		-	5~18V	16~30V	9~36V	5~36V	5.5~18V	5~20V	8~20V	
Gate Driver		-	3P+3N	3P+3N	3P+3N	3P+3N	6N	6N	6N	
Integrated MOS		N	Y	N	N	N	N	N	N	
Maximum power supply for driver		-	20V	30V	40V	40V	20V	25V	25V	
Maximum high side floating VB voltage		-	-	-	-	-	90V	200V	225V	
MCU working voltage		2.1V~5.5V								
Max. clock frequency		64MHz								
Memory	APROM	28/30/31/32KB ⁽¹⁾								
	BOOT	0/1/2/4KB ⁽¹⁾								
	Data Flash	1KB								
	SRAM	8KB								
Timer	SysTick	1 (24-bit)								
	WDT	1								
	WWDT	1								
	TIMER0/1	2 (16/32-bit)								
Enhanced digital peripherals	CRC	CRC-16-CCITT								
	divider	32 / 32 bit								
	CCP	2								
	EPWM	6(16-bit)								
Communication interfaces	UART	2								
	I2C	1								
	SSP/SPI	1								
Analog module	12bit-ADC0 (no. external channels)	22,30	22	7, 14	13, 23	13	24	24	24	
	12bit-ADC1 (no. external channels)	22,30	22	7, 14	13, 23	13	24	24	24	
	ACMP	2 ⁽²⁾	2	1	1 ⁽⁴⁾ , 2	1	2	2	2	
	OP	2	2	1 ⁽³⁾ , 2	2	2	2	2	2	
	PGA	2	2	2 ⁽²⁾	1 ⁽⁴⁾ , 2	1	2	2	2	
GPIOs		22	22	7, 14	13, 23	13	24	24	24	
LVR		1.9V/2.1V/2.6V								
LVD		2.0V/2.2V/2.4V/2.7V/3.0V/3.7V								
Working temperature		-40~105°C			-40~85°C			-40~105°C		
Packaging		SSOP24	QFN40	SOP16 SSOP24	SSOP24 TSSOP24 QFN40	SSOP24	QFN40 LQFP48	QFN40 LQFP48	LQFP48	

Note:

- 1) Set the APROM and BOOT space size by system configuration register, APROM and BOOT have max. space 32K.
- 2) Indicates number of analog modules, analog function is not achieved via pin's I/O, which subject to actual product.
- 3) Indicates SOP16 packaging has OP module 1.
- 4) Indicates the number of CMS32M5526S024/CMS32M5526TS024 comparator/PGA is 1.
- 5) The CMS32M5526xxx chip is relatively hot due to the driver chip itself. To ensure the normal operation of the MCU, the chip's operating ambient temperature should not exceed 85°C.

2. System Description

2.1 System Introduction

This series of products has integrated ARM[®] Cortex[®]-M0 with Nested Vectored Interrupt Controller. It has parallel I/O interface (support normal input, pull up/down input, push-pull output, leakage opening output and can configure edge/level triggered interrupt), timer (6-bit windowed watchdog timer, 32-bit watchdog timer, 2 programmable timer), SPI, I2C, UART, PWM, CCP, ADC, ACMP, OPA, PGA and other devices. Their main features are as follows:

- Max. 32KB FLASH memory space, max. 8KB SRAM memory, 1KB FLASH data space.
- Support BOOT and separated write-protection of programs, support hardware CRC verification of FLASH spatial code, register protection with user-defined ID, hence it is more secure.
- Provide choice of normal mode, sleep mode, deep sleep mode. It is more convenient and less power consuming.
- Contain 32-bit hardware divider and 32-bit single period hardware multiplier to achieve faster calculation
- Can configure any I/O interface as serial transmit/receive interface meanwhile, it can configure any I/O interface as input interface of ADC. Therefore, it is more convenient.
- Contains enhanced PWM with dead-time insertion, duty cycle interval update and individual/ complementary/ synchronized output.
- Contains strong analog IP such as 12-bit ADC with max. 1.2Msps, support analog comparator with choice hysteresis, programmable gain amplifier with adjustable gain and operational amplifier.

2.2 Register Map

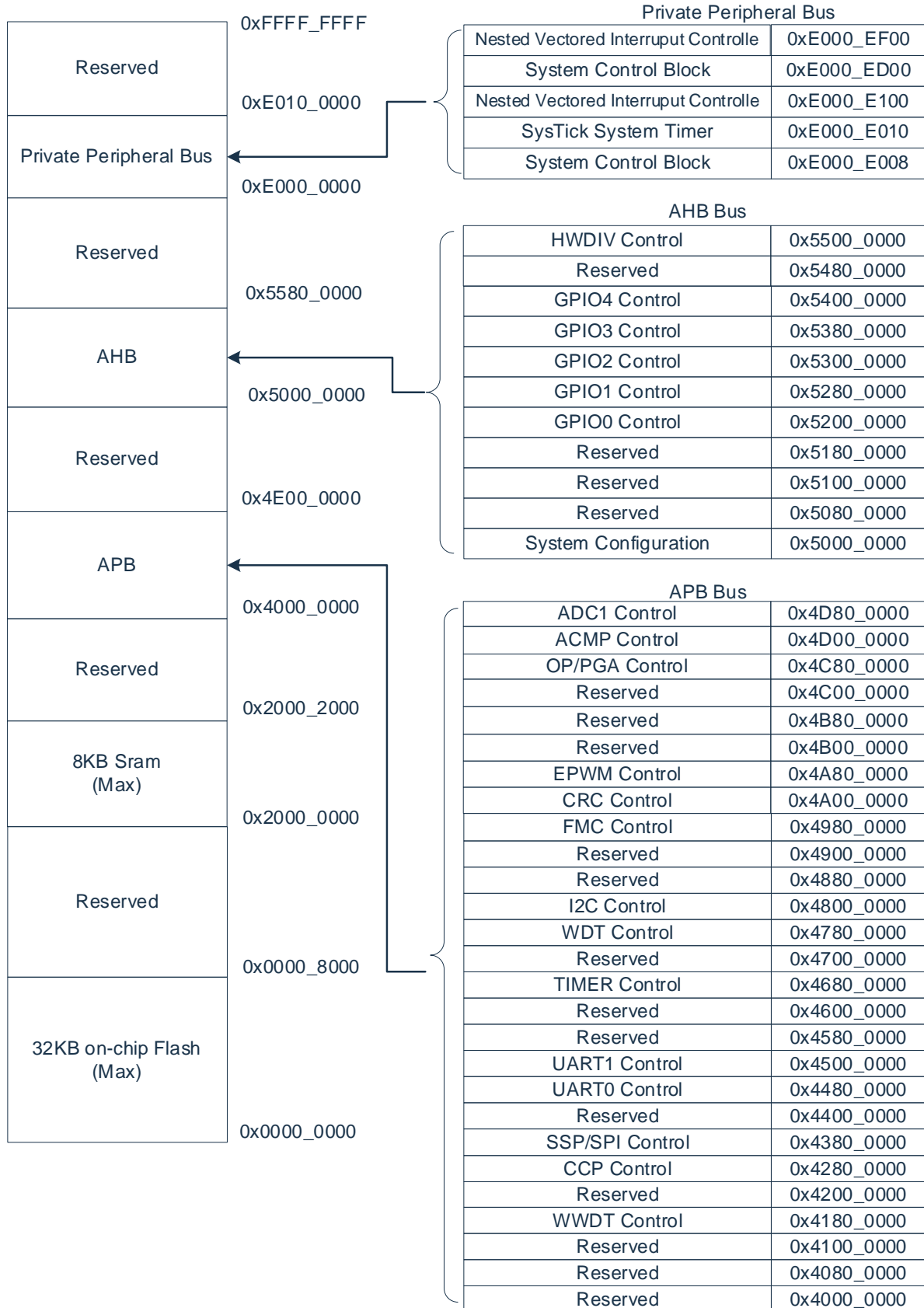

2.3 System Structure

2.3.1 CMS32M5510

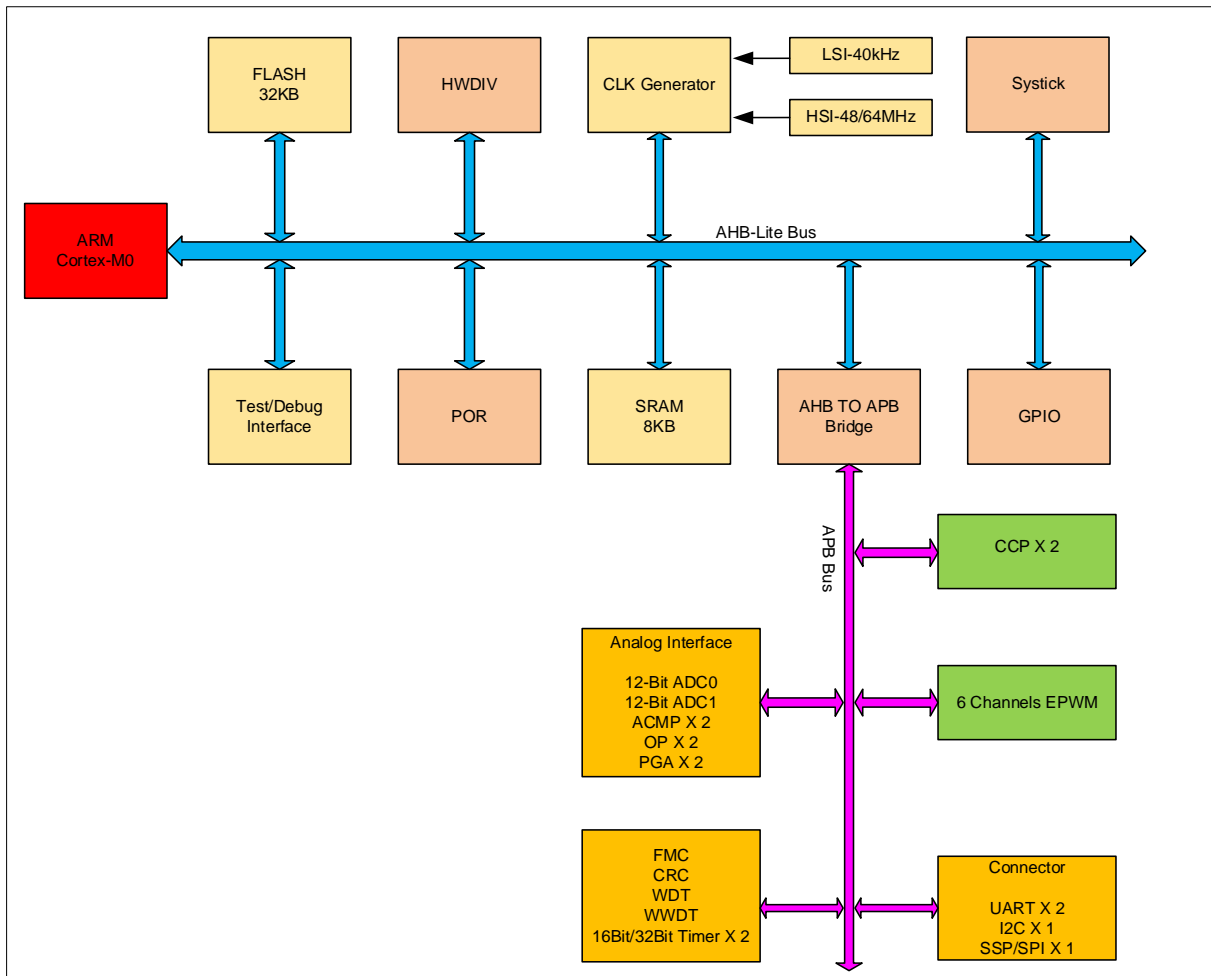

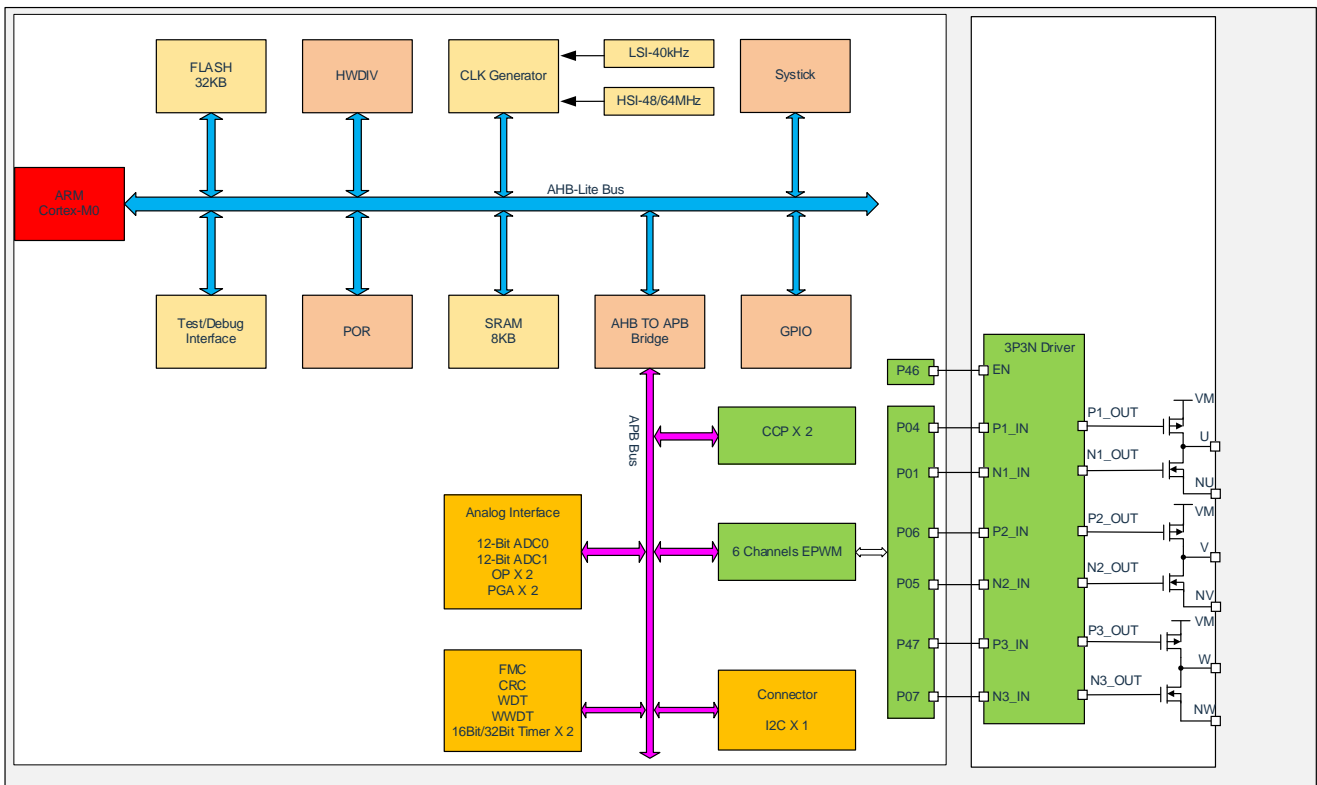
2.3.2 CMS32M5512

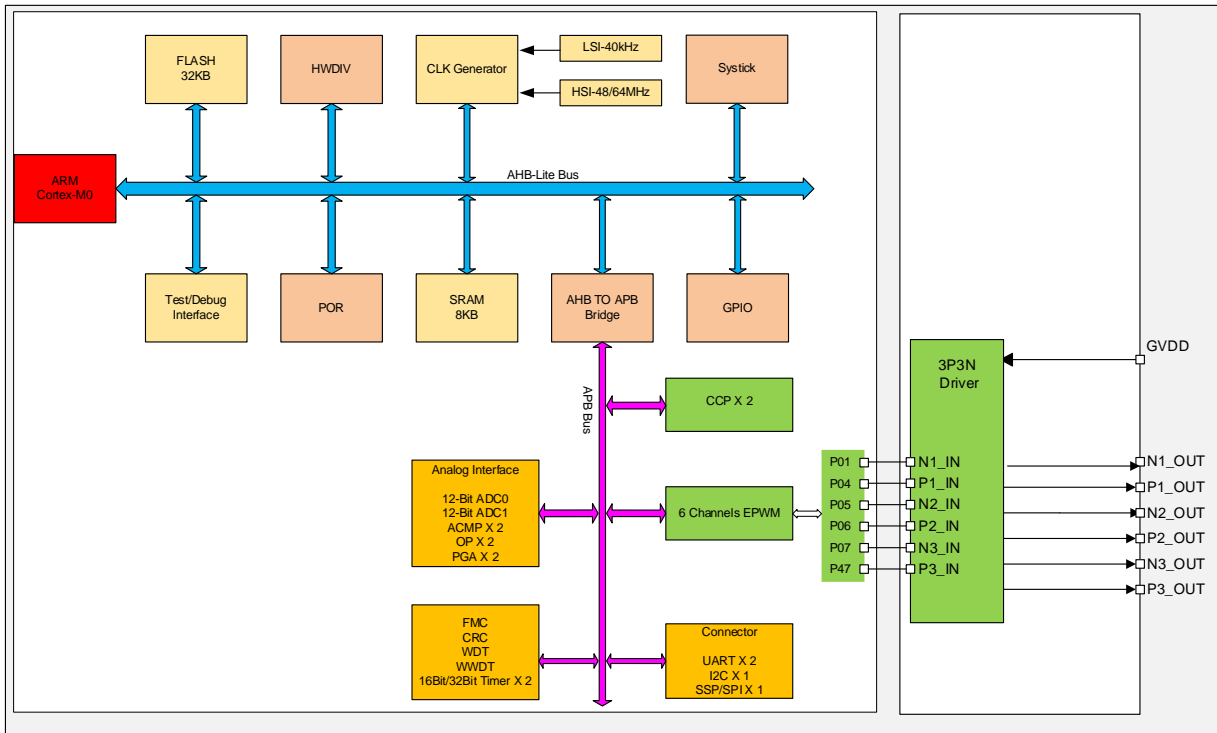
2.3.3 CMS32M5524

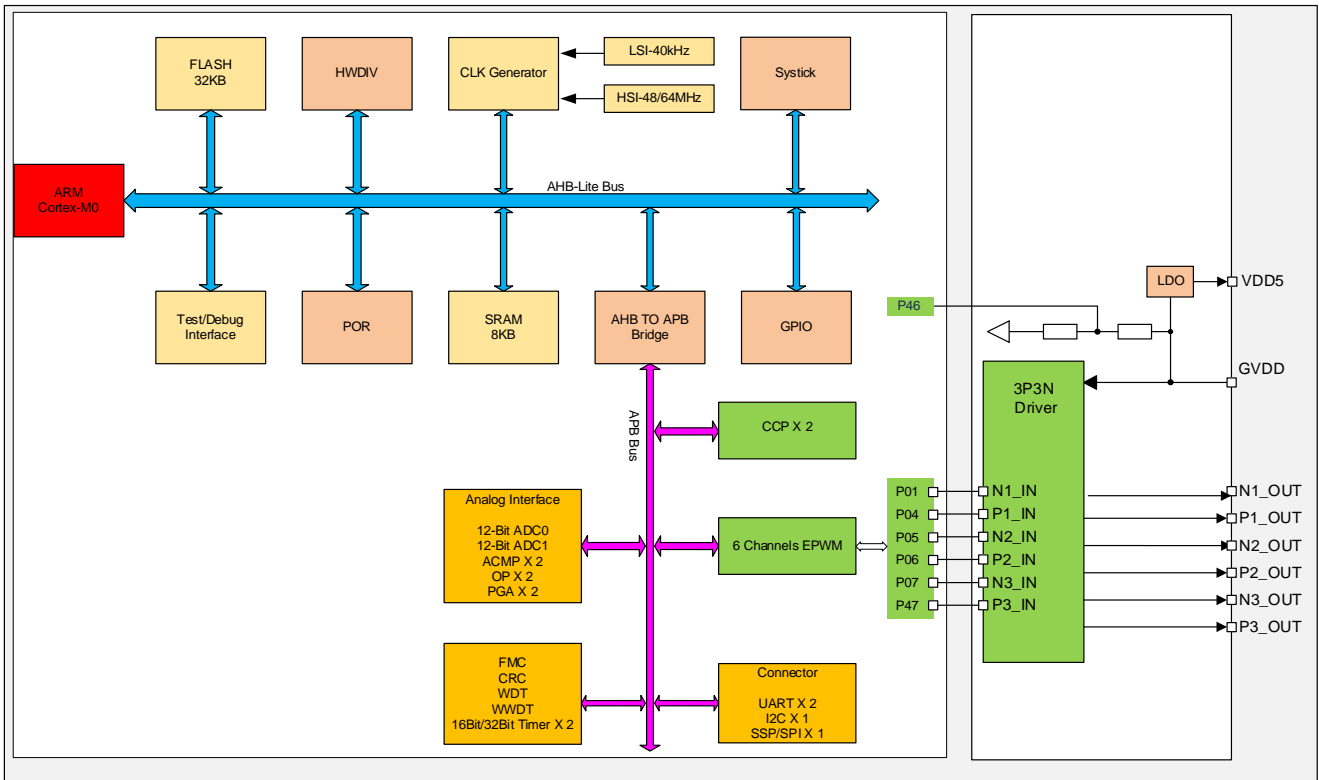
2.3.4 CMS32M5526/CMS32M5526C

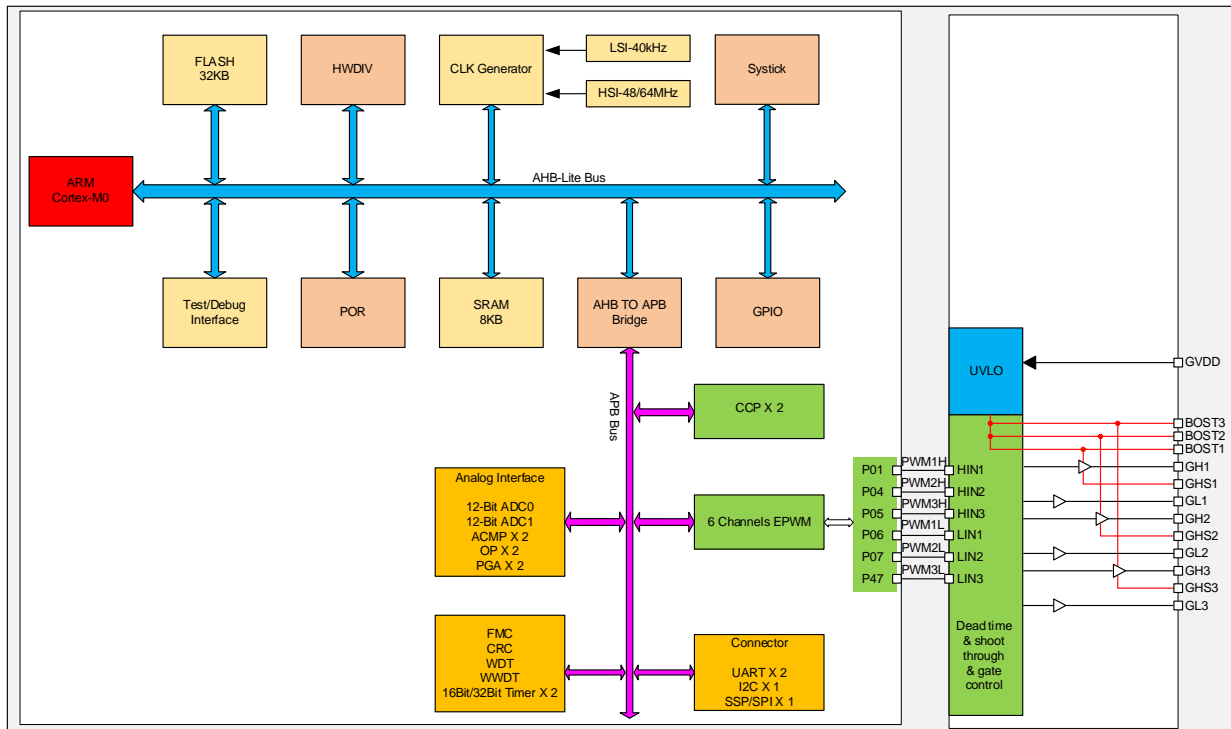
2.3.5 CMS32M5533/CMS32M5533E

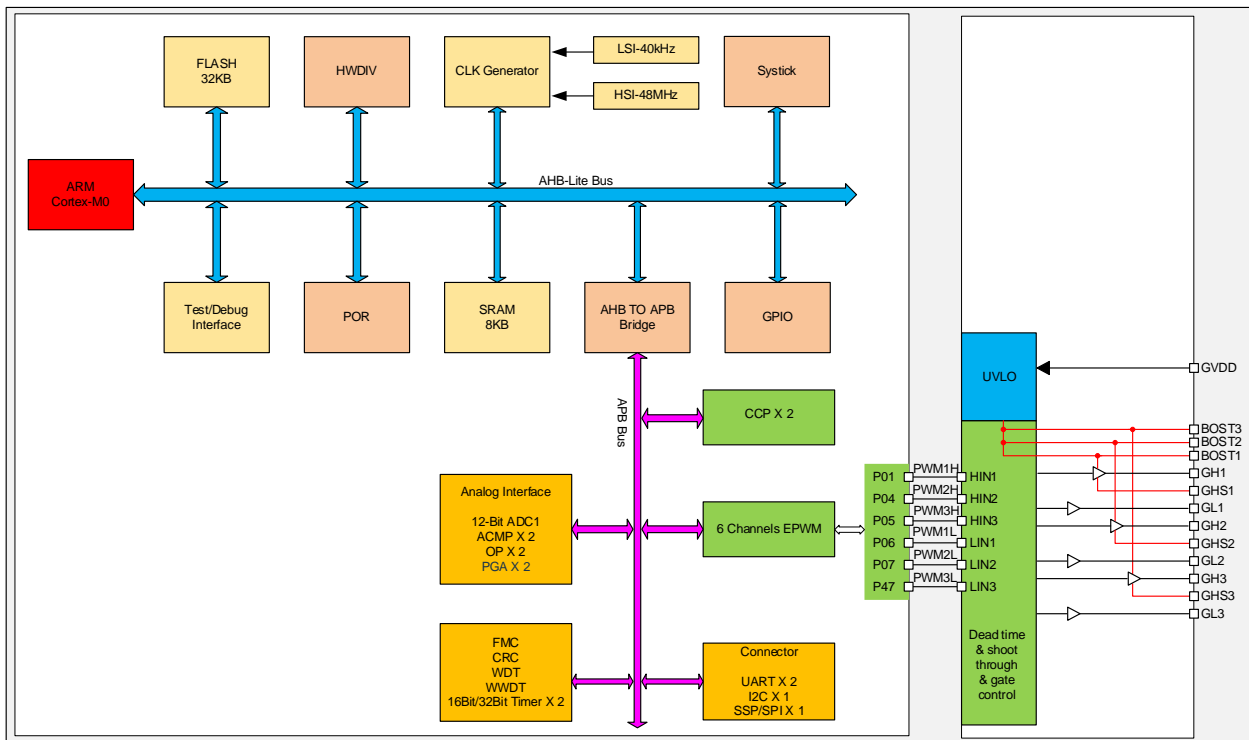
2.3.6 CMS32M5536

3. Pin Configuration

3.1 Pin Description

3.1.1 CMS32M5510(SSOP24)

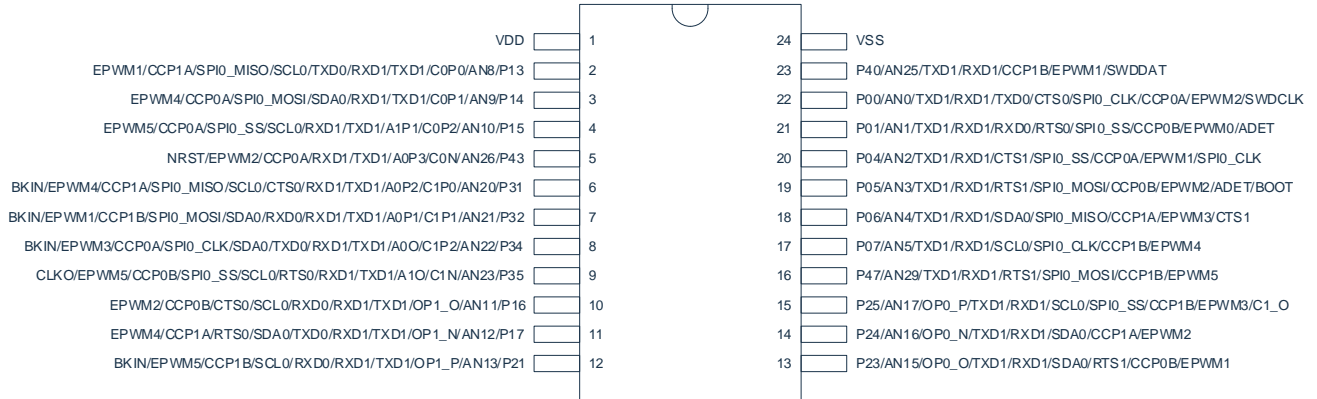

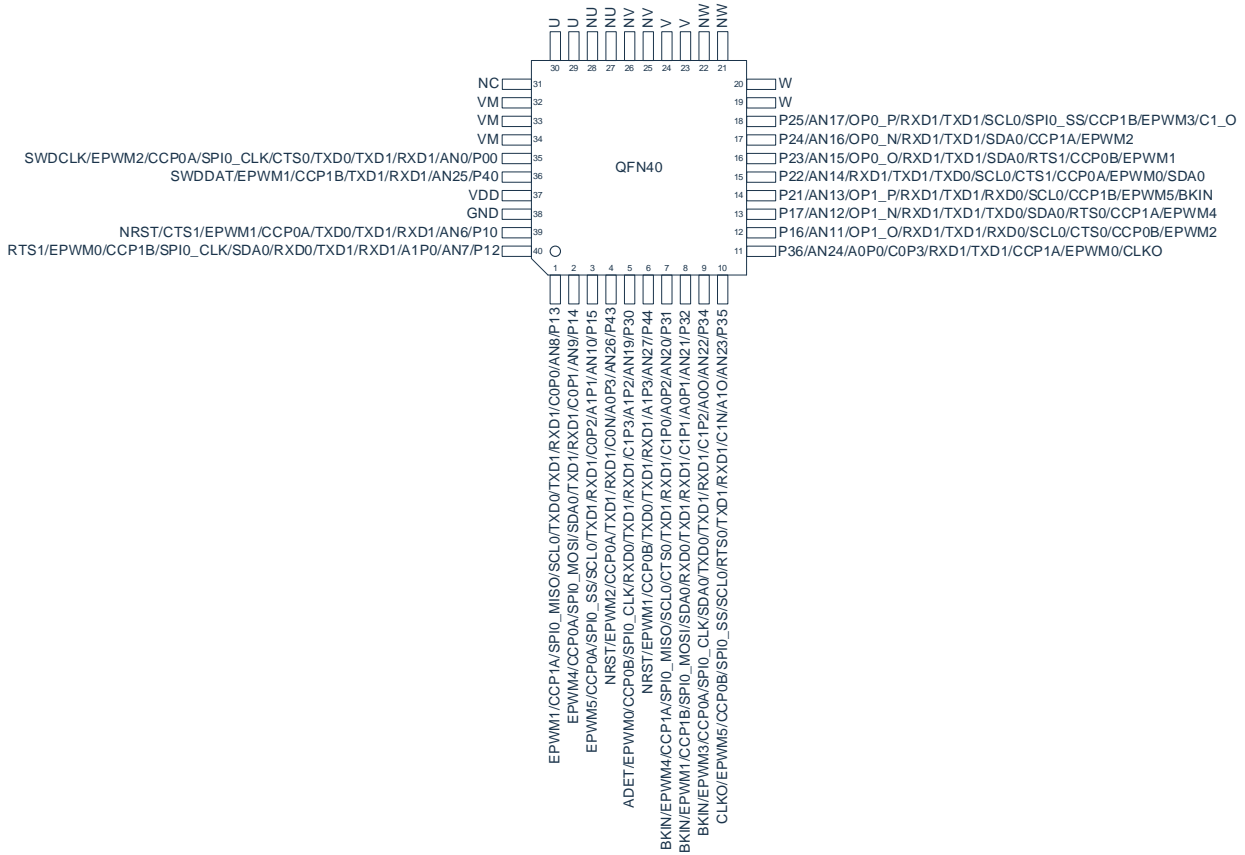
3.1.2 CMS32M5512(QFN40)

3.1.3 CMS32M5524(SOP16)

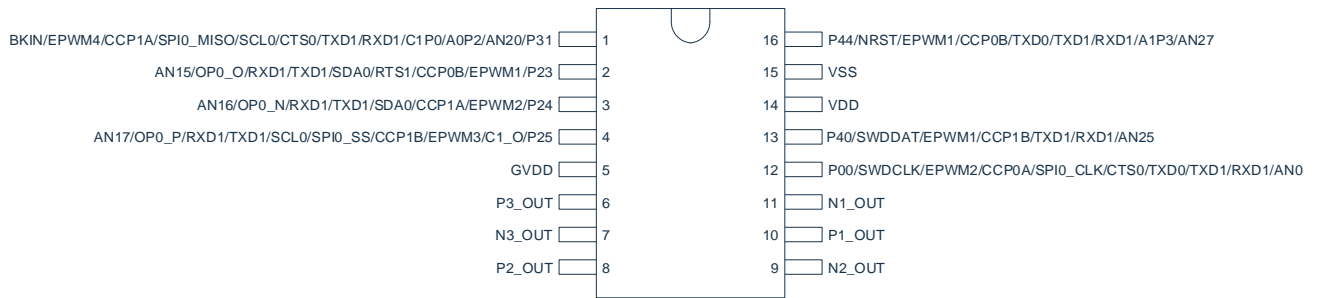

3.1.4 CMS32M5524(SSOP24)

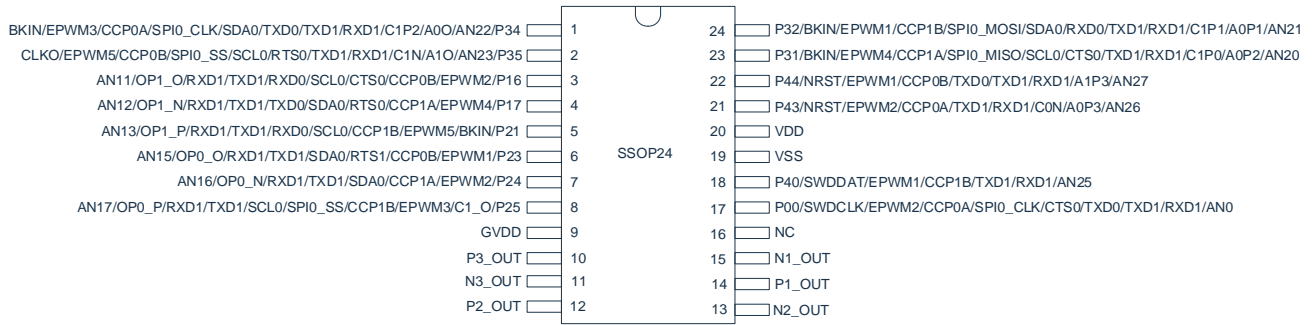

3.1.5 CMS32M5526(SSOP24/TSSOP24)

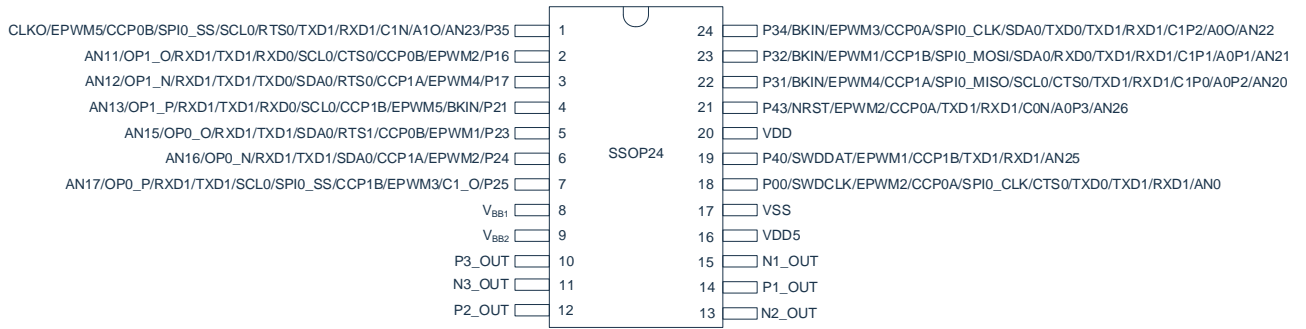

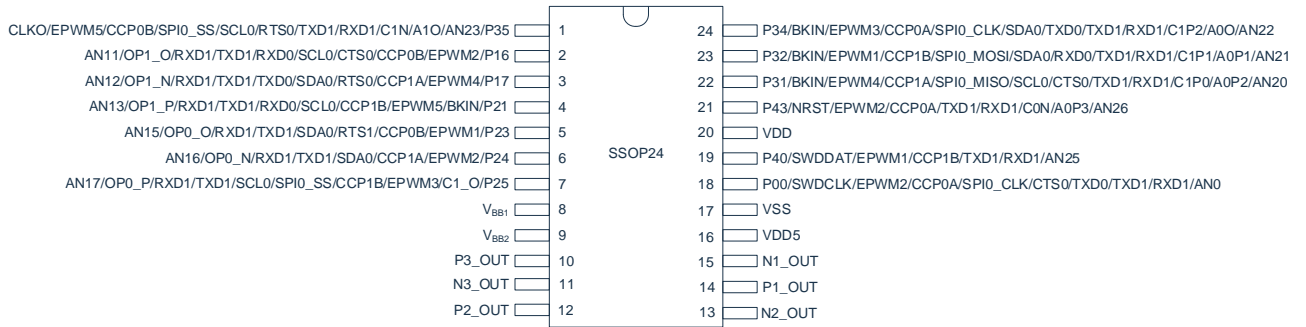
3.1.6 CMS32M5526C(SSOP24)

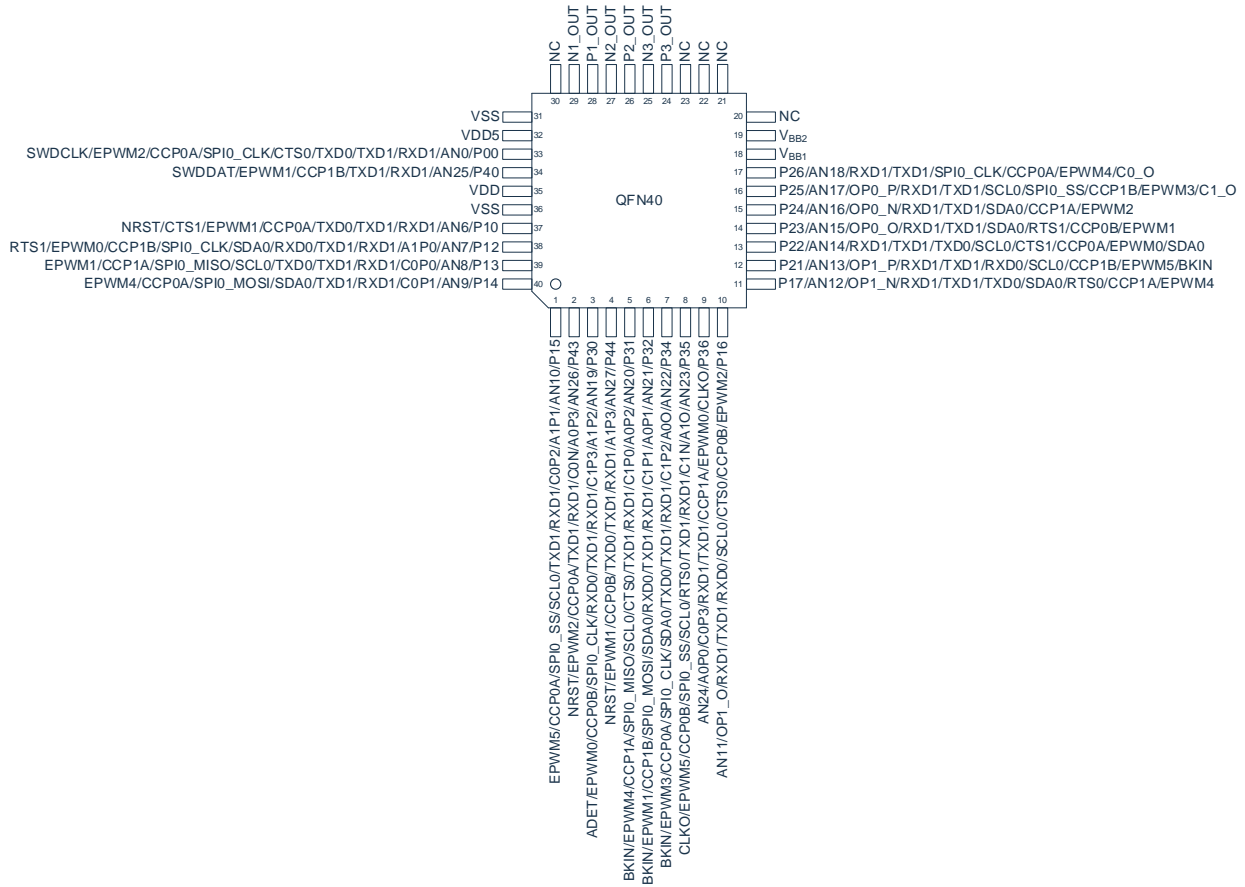
3.1.7 CMS32M5526(QFN40)

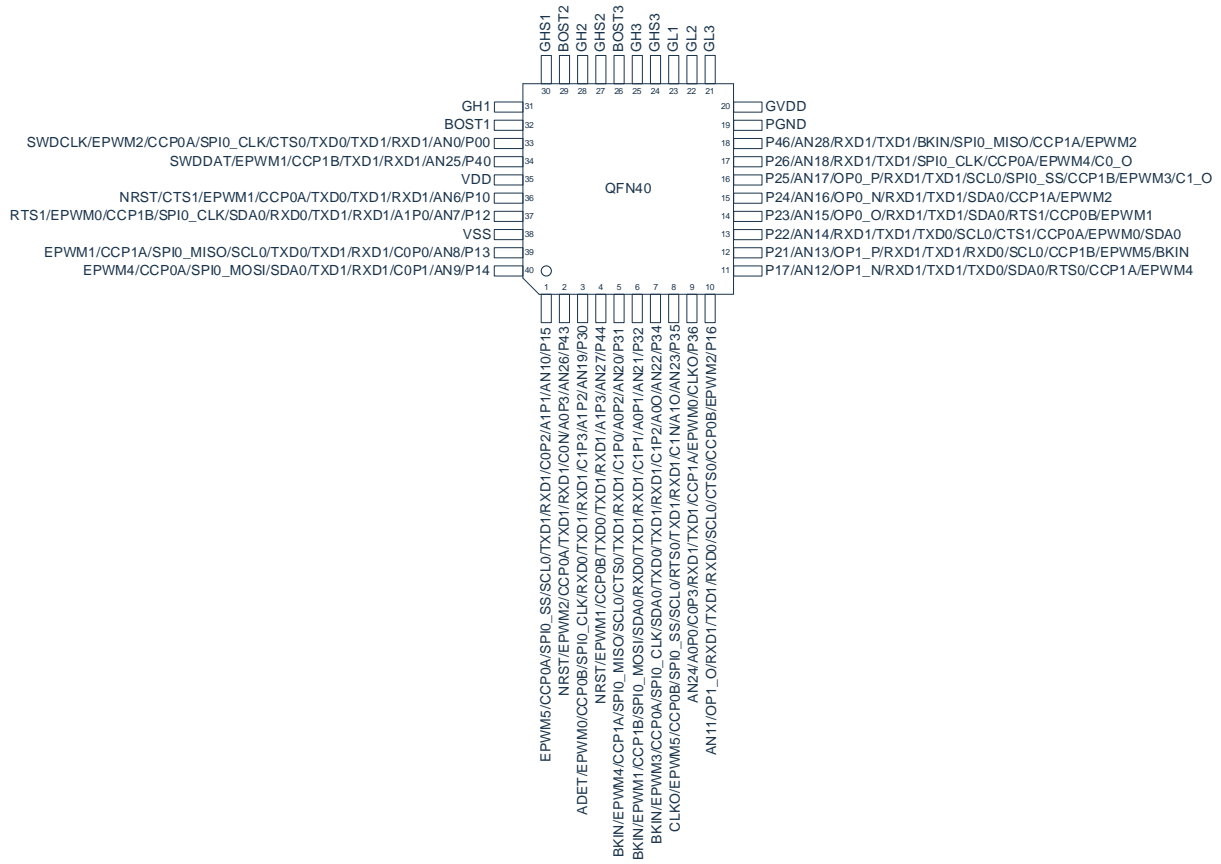
3.1.8 CMS32M5533/CMS32M5533E (QFN40)

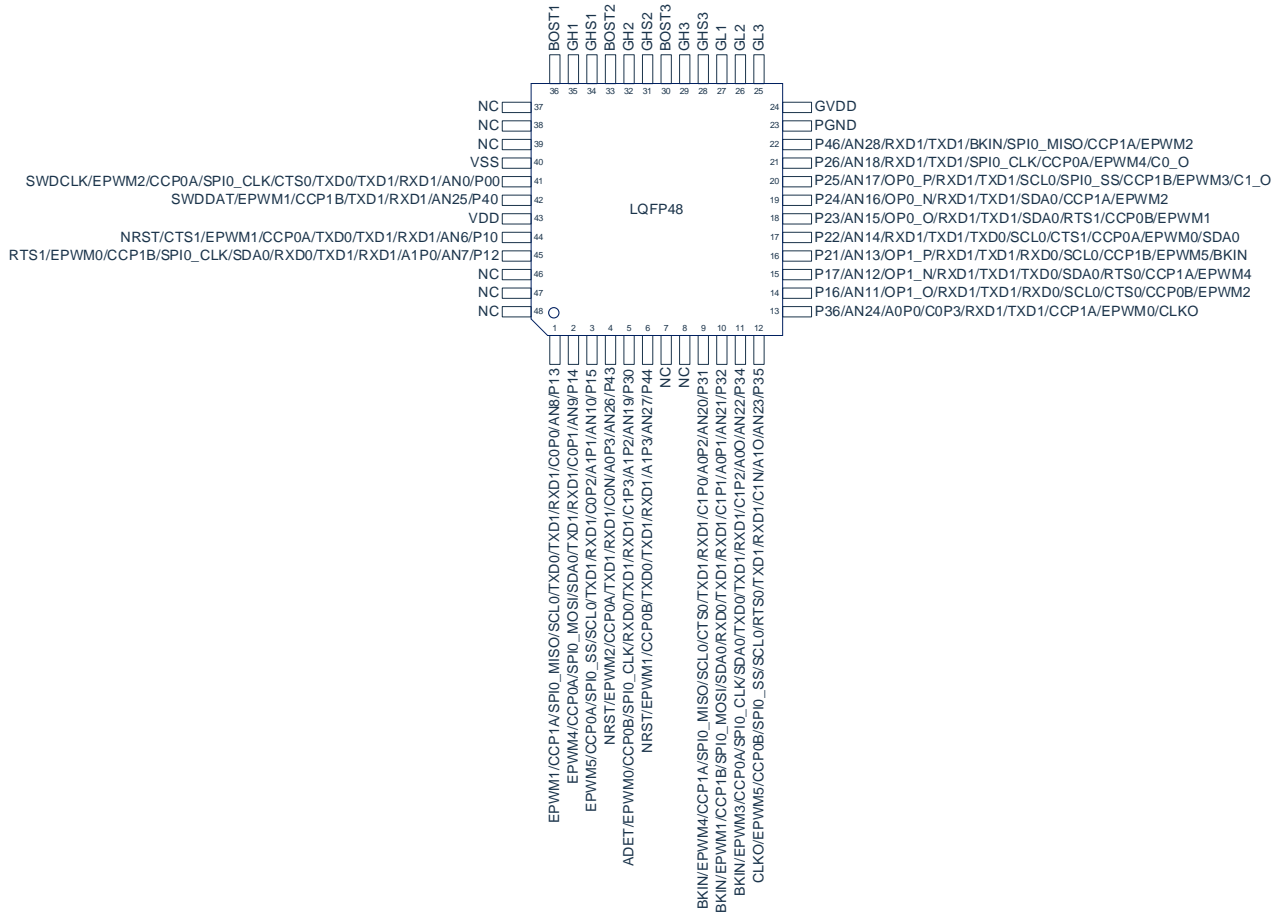
3.1.9 CMS32M5533/CMS32M5533E (LQFP48)

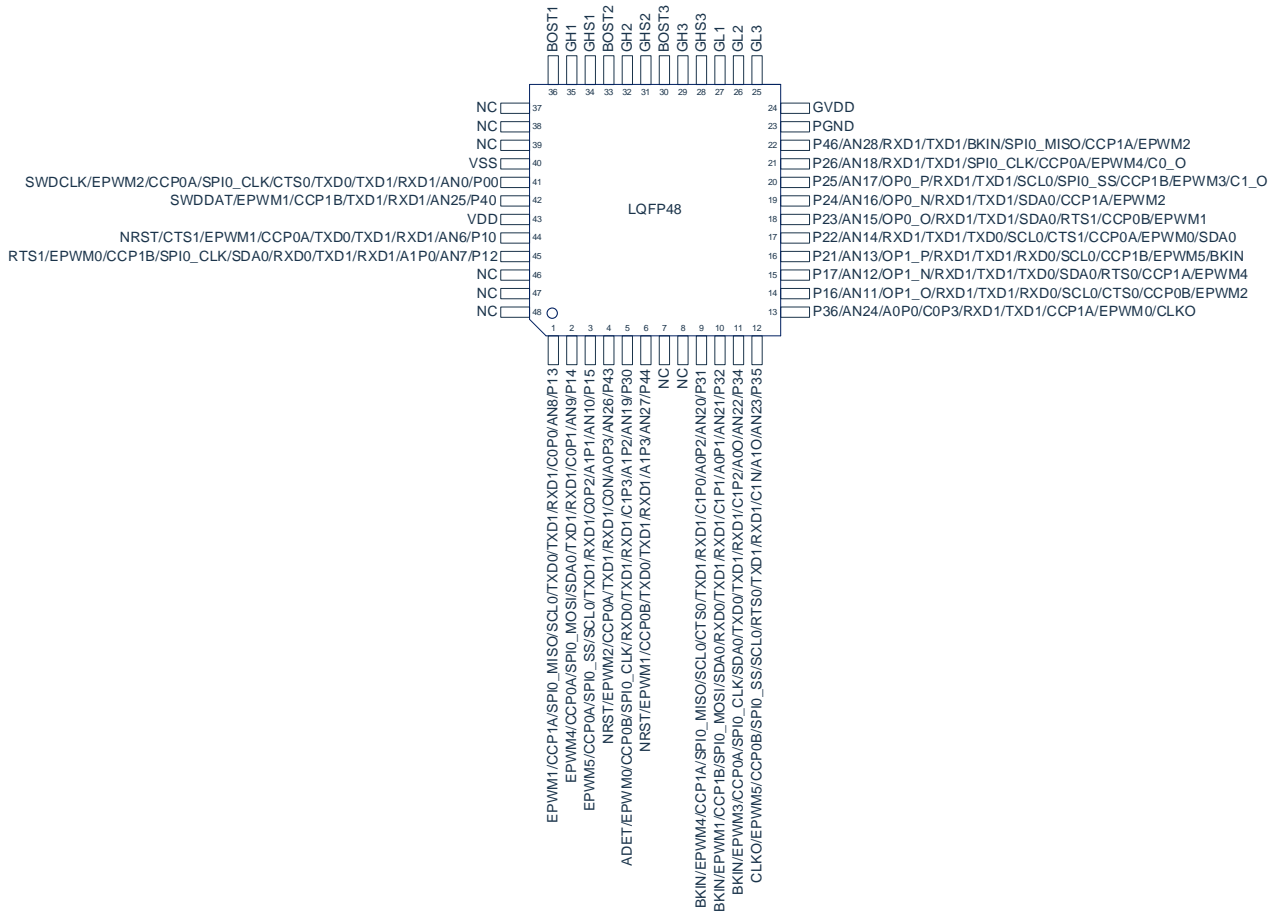
3.1.10 CMS32M5536(LQFP48)

3.2 Pin functions Description

Pin name	Symbol description
I/O	Digital input/output.
I	Digital input.
O	Digital output.
AI	Analog input.
AO	Analog output.
P	GND or VDD

3.2.1 CMS32M5510/12/24/26/26C Function description

Pin Number							Pin name	Pin type	Description
5510	5512	5524		5526C	5526				
SSOP 24	QFN 40	SOP 16	SSOP 24	SSOP 24	SSOP24/ TSSOP 24	QFN 40			
2	1	-	-	-	-	39	P13	I/O	General input/output pin
							AN8	AI	ADC analog input pin 8
							C0P0	AI	ACMP0 positive input channel 0
							ECAP00	I	ACMP0 positive input channel 0 as input capture
							TXD1	O	UART1 data output pin
							RXD1	I	UART1 data input pin
							TXD0	O	UART0 data output pin
							SCL0	I/O	I2C0 clock input/output pin
							SPI0_MISO	I/O	SPI0 master input/ slave output pin
							CCP1A	I/O	CCP1 input capture/ PWM output A pin
							EPWM1	O	EPWM output channel1
3	2	-	-	-	-	40	P14	I/O	General input/output pin
							AN9	AI	ADC analog input pin
							C0P1	AI	ACMP0 positive input channel 1
							ECAP01	I	ACMP0 positive input channel1 as input capture
							TXD1	O	UART1 data output pin
							RXD1	I	UART1 data input pin
							SDA0	I/O	I2C0 data input/output pin
							SPI0_MOSI	I/O	SPI0 master output/slave input pin
							CCP0A	I/O	CCP0 input capture/PWM output A pin
							EPWM4	O	EPWM output channel 4
4	3	-	-	-	-	1	P15	I/O	General input/output pin
							AN10	AI	ADC analog input channel 10
							C0P2	AI	ACMP0 positive input channel 2
							ECAP02	I	ACMP0 positive input channel 2 as input capture
							A1P1	AI	PAG1 positive input channel 1
							TXD1	O	UART1 data output pin
							RXD1	I	UART1 data input pin
							SCL0	I/O	I2C0 clock input/output pin
							SPI0_SS	I/O	SPI0 slave select pin

							CCP0A	I/O	CCP0 input capture/PWM output A pin
							EPWM5	O	EPWM output channel 5
5	4	-	21	21	21	2	P43	I/O	General input/output pin
							AN26	AI	ADC analog input channel 26
							C0N	AI	ACMP0 negative input channel
							A0P3	AI	PAG0 positive input channel 3
							TXD1	O	UART1 data output pin
							RXD1	I	UART1 data input pin
							NRST	I	External reset pin
							CCP0A	I/O	CCP0 input capture/PWM output A pin
						EPWM2	O	EPWM output channel2	
-	5	-	-	-	-	3	P30	I/O	General input/output pin
							AN19	AI	ADC analog input channel 19
							C1P3	AI	ACMP1 positive input channel 3
							ECAP13	I	ACMP1 positive input channel 3 as input capture
							A1P2	AI	PAG1 positive input channel 2
							TXD1	O	UART1 data output pin
							RXD1	I	UART1 data input pin
							RXD0	I	UART0 data input pin
							SPI0_CLK	I/O	SPI0 clock input/output pin
							CCP0B	I/O	CCP0 input capture/PWM output B pin
						EPWM0	O	EPWM outputchannel0	
						ADET	I	ADC external enabled digital input	
-	6	16	22	-	-	4	P44	I/O	general input/output pin
							AN27	AI	ADC analog input channel 27
							A1P3	AI	PAG1 positive input channel 3
							TXD1	O	UART1 data output pin
							RXD1	I	UART1 data input pin
							NRST	I	External reset pin
							TXD0	O	UART0 data output pin
							CCP0B	I/O	CCP0 input capture/ PWM output B pin
EPWM1	O	EPWM outputchannel1							
-	31	-	16	-	-	20,21,22,23,30	NC	-	Not connected
6	7	1	23	22	22	5	P31	I/O	General input/output pin
							AN20	AI	ADC analog input channel 20
							C1P0	AI	ACMP1 positive input channel 0
							ECAP10	I	ACMP1 positive input channel 0 as input capture
							A0P2	AI	PAG0 positive input channel 2
							TXD1	O	UART1 data output pin
							RXD1	I	UART1 data input pin
							CTS0	I	UART0 clear to send pin
							SCL0	I/O	I2C0 clock input/output pin
							SPI0_MISO	I/O	SPI0 master input/slave output pin
							CCP1A	I/O	CCP input capture/PWM0output A pin
							BKIN	I	EPWM brake input
EPWM4	O	EPWM outputchannel4							

7	8	-	24	23	23	6	P32	I/O	General input/output pin
							AN21	AI	ADC analog input channel 21
							C1P1	AI	ACMP1 positive input channel 1
							ECAP11	I	ACMP1 positive input channel1 as input capture
							A0P1	AI	PAG0 positive input channel 1
							TXD1	O	UART1 data output pin
							RXD1	I	UART1 data input pin
							RXD0	I	UART0 data input pin
							SDA0	I/O	I2C0 data input/output pin
							SPI0_MOSI	I/O	SPI0 master output/slave input pin
							CCP1B	I/O	CCP1 input capture/PWM output B pin
							BKIN	I	EPWM brake input
							EPWM1	O	EPWM output channel 1
8	9	-	1	24	24	7	P34	I/O	General input/output pin
							AN22	AI	ADC analog input channel 22
							C1P2	AI	ACMP1 positive input channel 2
							ECAP12	I	ACMP1 positive input channel 2as input capture
							A0O	AO	PAG0 output channel
							TXD1	O	UART1 data output pin
							RXD1	I	UART1 data input pin
							TXD0	O	UART0 data output pin
							SDA0	I/O	I2C0 data input/output pin
							SPI0_CLK	I/O	SPI0 clock input/output pin
							CCP0A	I/O	CCP0 input capture/PWM output A pin
							BKIN	I	EPWM brake input
							EPWM3	O	EPWM output channel 3
9	10	-	2	1	1	8	P35	I/O	General input/output pin
							AN23	AI	ADC analog channel23
							C1N	AI	ACMP1 negative input channel
							A1O	AO	PAG1 output channel
							TXD1	O	UART1 data output pin
							RXD1	I	UART1 data input pin
							RTS0	O	UART0 request to send pin
							SCL0	I/O	SPI0 clock input/output pin
							SPI0_SS	I/O	SPI0 slave select pin
							CCP0B	I/O	CCP0 input capture/PWM output B pin
							EPWM5	O	EPWM output channel 5
							CLKO	O	System clock output pin
-	11	-	-	-	-	9	P36	I/O	General input/output pin
							AN24	AI	ADC analog channel 23
							C0P3	AI	ACMP0 positive input channel 3
							ECAP03	I	ACMP0 positive input channel 3as input capture
							A0P0	AI	PAG0 positive input channel 0
							TXD1	O	UART1 data output pin
							RXD1	I	UART1 data input pin
							CCP1A	I/O	CCP1 input capture/PWM output A pin
EPWM0	O	EPWM output channel 0							

							CLKO	O	System clock output pin
10	12	-	3	2	2	10	P16	I/O	General input/output pin
							AN11	AI	ADC analog channel11
							OP1_O	AO	OPA1 output channel
							TXD1	O	UART1 data output pin
							RXD1	I	UART1 data input pin
							RXD0	I	UART0 data input pin
							SCL0	I/O	I2C0 clock input/output pin
							CTS0	I	UART0 clear to send pin
							CCP0B	I/O	CCP0 input capture/PWM output B pin
EPWM2	O	EPWM output channel2							
11	13	-	4	3	3	11	P17	I/O	General input/output pin
							AN12	AI	ADC analog channel12
							OP1_N	AI	OPA1 negative input
							TXD1	O	UART1 data output pin
							RXD1	I	UART1 data input pin
							TXD0	O	UART0 data output pin
							SDA0	I/O	I2C0 data input/output pin
							RTS0	O	UART0 request to send pin
							CCP1A	I/O	CCP1 input capture/PWM output A pin
EPWM4	O	EPWM output channel4							
12	14	-	5	4	4	12	P21	I/O	General input/output pin
							AN13	AI	ADC analog channel13
							OP1_P	AI	OPA1 positive input
							TXD1	O	UART1 data output pin
							RXD1	I	UART1 data input pin
							RXD0	I	UART0 data input pin
							SCL0	I/O	I2C0 clock input/output pin
							CCP1B	I/O	CCP1 input capture/PWM output B pin
							BKIN	I	EPWM brake input
EPWM5	O	EPWM output channel5							
-	15	-	-	-	-	13	P22	I/O	general input/output pin
							AN14	AI	ADC analog channel 14
							TXD1	O	UART1 data output pin
							RXD1	I	UART1 data input pin
							TXD0	O	UART0 data output pin
							SCL0	I/O	I2C0 clock input/output pin
							CTS1	I	UART0 clear to send pin
							CCP0A	I/O	CCP0 input capture/PWM output A pin
							EPWM0	O	EPWM output channel 0
SDA0	I/O	I2C0 data input/output pin							
13	16	2	6	5	5	14	P23	I/O	General input/output pin
							AN15	AI	ADC analog channel15
							OP0_O	AO	OPA0 output channel
							TXD1	O	UART1 data output pin
							RXD1	I	UART1 data input pin
							SDA0	I/O	I2C0 data input/output pin
							RTS1	O	UART1 request to send pin
							CCP0B	I/O	CCP0 input capture/PWM output B pin

							EPWM1	O	EPWM output channel1
14	17	3	7	6	6	15	P24	I/O	General input/output pin
							AN16	AI	ADC analog channel16
							OP0_N	AI	OPA0 negative input channel
							TXD1	O	UART1 data output pin
							RXD1	I	UART1 data input pin
							SDA0	I/O	I2C0 data input/output pin
							CCP1A	I/O	CCP1 input capture/PWM output A pin
							EPWM2	O	EPWM output channel2
15	18	4	8	7	7	16	P25	I/O	General input/output pin
							AN17	AI	ADC analog channel17
							OP0_P	AI	OPA0 positive input channel
							TXD1	O	UART1 data output pin
							RXD1	I	UART1 data input pin
							SCL0	I/O	I2C0 clock input/output pin
							SPI0_SS	I/O	SPI0 slave select pin
							CCP1B	I/O	CCP1 input capture/PWM output B pin
							EPWM3	O	EPWM output channel3
							C1_O	O	ACMP1 output channel
-	-	-	-	-	-	17	P26	I/O	General input/output pin
							AN18	AI	ADC analog channel 18
							TXD1	O	UART1 data output pin
							RXD1	I	UART1 data input pin
							SPI0_CLK	I/O	SPI0 clock input/output pin
							CCP0A	I/O	CCP0 input capture/PWM output A pin
							EPWM4	O	EPWM output channel 4
							C0_O	O	ACMP0 output channel
-	-	5	9	-	-	-	GVDD	P	Internal generated power supply pin
-	-	-	-	8	8	18	V _{BB1}	P	5V power supply terminal
-	-	-	-	9	9	19	V _{BB2}	P	Drive power supply terminal
-	19,2 0	-	-	-	-	-	W	O	W phase output
-	21,2 2	-	-	-	-	-	NW	O	W-phase low-side N power tube source pole
-	23,2 4	-	-	-	-	-	V	O	V phase output
-	25,2 6	-	-	-	-	-	NV	O	V-phase low-side N power tube source pole
-	27,2 8	-	-	-	-	-	NU	O	U-phase low-side N power tube source pole
-	29,3 0	-	-	-	-	-	U	O	U phase output
-	32,3 3,34	-	-	-	-	-	VM	P	Power side
24	38	15	19	17	17	31,36	VSS/GND	P	Voltage source supply(ground)
22	35	12	17	18	18	33	P00	I/O	General input/output pin
							AN0	AI	ADC analog channel 0
							TXD1	O	UART1 data output pin
							RXD1	I	UART1 data input pin
							TXD0	O	UART0 transmit data output pin
							CTS0	I	UART0 clear to send pin
							SPI0_CLK	I/O	SPI0 clock input/output pin
							CCP0A	I/O	PWM0 input capture/PWM output A

									pin	
								EPWM2	O	EPWM output channel2
								SWDCLK	I	SWD programming, debugging clock input pin
23	36	13	18	19	19	34	P40	I/O	General input/output pin	
							AN25	AI	ADC analog input channel 25	
							TXD1	O	UART1 data output pin	
							RXD1	I	UART1 data input pin	
							CCP1B	I/O	CCP1 input capture/PWM output B pin	
							EPWM1	O	EPWM output channel1	
							SWDDAT	I/O	SWD programming, debugging data input/output pin	
1	37	14	20	20	20	35	VDD	P	Power supply	
-	-	-	-	16	16	32	VDD5	P	5V Poweroutput	
							P10	I/O	General input/output pin	
							AN6	AI	ADC analog input channel 6	
							TXD1	O	UART1 data output pin	
							RXD1	I	UART1 data input pin	
-	39	-	-	-	-	38	TXD0	O	UART0 data output pin	
							NRST	I	External reset pin	
							CCP0A	I/O	CCP0 input capture/PWM output A pin	
							EPWM1	O	EPWM output channel1	
							CTS1	I	UART1 clear to send pin	
							P12	I/O	General input/output pin	
							AN7	AI	ADC analog input pin7	
							A1P0	AI	PAG1 positive input channel 0	
							TXD1	O	UART1 data output pin	
							RXD1	I	UART1 data input pin	
-	40	-	-	-	-	37	RXD0	I	UART0 data input pin	
							SDA0	I/O	I2C0 data input/output pin	
							SPI0_CLK	I/O	SPI0 clock input/output pin	
							CCP1B	I/O	CCP1 input capture/PWM output B pin	
							EPWM0	O	EPWM output channel 0	
							RTS1	O	UART1 request to send pin	
-	-	6	10	10	10	24	P3_OUT	O	P3 output signal	
-	-	7	11	11	11	25	N3_OUT	O	N3 output signal	
-	-	8	12	12	12	26	P2_OUT	O	P2 output signal	
-	-	9	13	13	13	27	N2_OUT	O	N2 output signal	
-	-	10	14	14	14	28	P1_OUT	O	P1 output signal	
-	-	11	15	15	15	29	N1_OUT	O	N1 output signal	
							P01	I/O	General input/output pin	
							AN1	AI	ADC analog channel 1	
							TXD1	O	UART1 data output pin	
							RXD1	I	UART1 data input pin	
21	-	-	-	-	-	-	RXD0	I	UART0 data input pin	
							RTS0	O	UART0 request to send pin	
							SPI0_SS	I/O	SPI0 salve select pin	
							CCP0B	I/O	CCP0 input capture/PWM output B pin	
							EPWM0	O	EPWM output channel 0	
							ADET	I	ADC external enable digital input	

20	-	-	-	-	-	-	P04	I/O	General input/output pin
							AN2	AI	ADC analog channel 2
							TXD1	O	UART1 data output pin
							RXD1	I	UART1 data input pin
							CTS1	I	UART1 request to send pin
							SPI0_SS	I/O	SPI0 salve select pin
							CCP0A	I/O	CCP0 input capture/PWM output B pin
							EPWM1	O	EPWM output channel 1
19	-	-	-	-	-	-	P05	I/O	General input/output pin
							AN3	AI	ADC analog channel 3
							TXD1	O	UART1 data output pin
							RXD1	I	UART1 data input pin
							RTS1	O	UART1 request to send pin
							SPI0_MOSI	I/O	SPI0 master input/slave output pin
							CCP0B	I/O	CCP0 input capture/PWM output B pin
							EPWM2	O	EPWM output channel 2f
							BOOT	I	BOOT configuration input pin
ADET	I	ADC external enable digital input							
18	-	-	-	-	-	-	P06	I/O	General input/output pin
							AN4	AI	ADC analog channel 4
							TXD1	O	UART1 data output pin
							RXD1	I	UART1 data input pin
							SDA0	I/O	I2C0 data input/output pin
							SPI0_MISO	I/O	SPI0 master input/slave output pin
							CCP1A	I/O	CCP1 input capture/PWM output A pin
							EPWM3	O	EPWM output channel 1
CTS1	I	UART1 request to send pin							
17	-	-	-	-	-	-	P07	I/O	General input/output pin
							AN5	AI	ADC analog channel 5
							TXD1	O	UART1 data output pin
							RXD1	I	UART1 data input pin
							SCL0	I/O	I2C0 clock input/output pin
							SPI0_CLK	I/O	SPI0 clock input/output pin
							CCP1B	I/O	CCP1 input capture/PWM output B pin
							EPWM4	O	EPWM output channel 4
16	-	-	-	-	-	-	P47	I/O	General input/output pin
							AN29	AI	ADC analog output 29
							TXD1	O	UART1 data output pin
							RXD1	I	UART1 data input pin
							RTS1	O	UART1 request to send pin
							SPI0_MOSI	I/O	SPI0 master input/slave output pin
							CCP1B	I/O	CCP1 input capture/PWM output B pin
EPWM5	O	EPWM output channel 5							
-	-	-	-	-	-	-	P46	I/O	General input/output pin
							AN28	AI	ADC analog output 28
							TXD1	O	UART1 data output pin
							RXD1	I	UART1 data input pin
							SPI0_MISO	I/O	SPI0 master output/slave input pin

							CCP1A	I/O	CCP1 input capture/PWM output A pin
							BKIN	I	EPWM brake input
							EPWM2	O	EPWM output channel 2

3.2.2 CMS32M5533/33E/36 Function description

Pin number			pin name	pin type	description
5533/5533E		5536			
LQFP48	QFN40	LQFP48			
1	39	1	P13	I/O	General input/output pin
			AN8	AI	ADC analog input pin 8
			C0P0	AI	ACMP0 positive input channel 0
			ECAP00	I	ACMP0 positive input channel 0 as input capture
			TXD1	O	UART1 data output pin
			RXD1	I	UART1 data input pin
			TXD0	O	UART0 data output pin
			SCL0	I/O	I2C0 clock input/output pin
			SPI0_MISO	I/O	SPI0 master input/ slave output pin
			CCP1A	I/O	CCP1 input capture/ PWM output A pin
			EPWM1	O	EPWM output channel1
2	40	2	P14	I/O	General input/output pin
			AN9	AI	ADC analog input pin
			C0P1	AI	ACMP0 positive input channel 1
			ECAP01	I	ACMP0 positive input channel1 as input capture
			TXD1	O	UART1 data output pin
			RXD1	I	UART1 data input pin
			SDA0	I/O	I2C0 data input/output pin
			SPI0_MOSI	I/O	SPI0 master output/slave input pin
			CCP0A	I/O	CCP0 input capture/PWM output A pin
			EPWM4	O	EPWM output channel 4
			3	1	3
AN10	AI	ADC analog input channel 10			
C0P2	AI	ACMP0 positive input channel 2			
ECAP02	I	ACMP0 positive input channel 2 as input capture			
A1P1	AI	PAG1 positive input channel 1			
TXD1	O	UART1 data output pin			
RXD1	I	UART1 data input pin			
SCL0	I/O	I2C0 clock input/output pin			
SPI0_SS	I/O	SPI0 slave select pin			
CCP0A	I/O	CCP0 input capture/PWM output A pin			
EPWM5	O	EPWM output channel 5			
4	2	4	P43	I/O	General input/output pin
			AN26	AI	ADC analog input channel 26
			C0N	AI	ACMP0 negative input channel
			A0P3	AI	PAG0 positive input channel 3
			TXD1	O	UART1 data output pin
			RXD1	I	UART1 data input pin
			NRST	I	External reset pin
			CCP0A	I/O	CCP0 input capture/PWM output A pin
			EPWM2	O	EPWM output channel2
5	3	5	P30	I/O	General input/output pin
			AN19	AI	ADC analog input channel 19
			C1P3	AI	ACMP1 positive input channel 3

Pin number			pin name	pin type	description
5533/5533E		5536			
LQFP48	QFN40	LQFP48			
			ECAP13	I	ACMP1 positive input channel 3 as input capture
			A1P2	AI	PAG1 positive input channel 2
			TXD1	O	UART1 data output pin
			RXD1	I	UART1 data input pin
			RXD0	I	UART0 data input pin
			SPI0_CLK	I/O	SPI0 clock input/output pin
			CCP0B	I/O	CCP0 input capture/PWM output B pin
			EPWM0	O	EPWM outputchannel0
			ADET	I	ADC external enabled digital input
6	4	6	P44	I/O	general input/output pin
			AN27	AI	ADC analog input channel 27
			A1P3	AI	PAG1 positive input channel 3
			TXD1	O	UART1 data output pin
			RXD1	I	UART1 data input pin
			NRST	I	External reset pin
			TXD0	O	UART0 data output pin
			CCP0B	I/O	CCP0 input capture/ PWM output B pin
EPWM1	O	EPWM outputchannel1			
7,8,37, 38,39, 46,47,4 8	-	7,8,37, 38,39,4 6,47,48	NC	-	Not connected
9	5	9	P31	I/O	General input/output pin
			AN20	AI	ADC analog input channel 20
			C1P0	AI	ACMP1 positive input channel 0
			ECAP10	I	ACMP1 positive input channel 0 as input capture
			A0P2	AI	PAG0 positive input channel 2
			TXD1	O	UART1 data output pin
			RXD1	I	UART1 data input pin
			CTS0	I	UART0 clear to send pin
			SCL0	I/O	I2C0 clock input/output pin
			SPI0_MISO	I/O	SPI0 master input/slave output pin
			CCP1A	I/O	CCP input capture/PWM0output A pin
			BKIN	I	EPWM brake input
EPWM4	O	EPWM outputchannel4			
10	6	10	P32	I/O	General input/output pin
			AN21	AI	ADC analog input channel 21
			C1P1	AI	ACMP1 positive input channel 1
			ECAP11	I	ACMP1 positive input channel1 as input capture
			A0P1	AI	PAG0 positive input channel 1
			TXD1	O	UART1 data output pin
			RXD1	I	UART1 data input pin
			RXD0	I	UART0 data input pin
			SDA0	I/O	I2C0 data input/output pin
			SPI0_MOSI	I/O	SPI0 master output/slave input pin
			CCP1B	I/O	CCP1 input capture/PWM output B pin
			BKIN	I	EPWM brake input

Pin number			pin name	pin type	description
5533/5533E		5536			
LQFP48	QFN40	LQFP48			
			EPWM1	O	EPWM output channel 1
11	7	11	P34	I/O	General input/output pin
			AN22	AI	ADC analog input channel 22
			C1P2	AI	ACMP1 positive input channel 2
			ECAP12	I	ACMP1 positive input channel 2as input capture
			A00	AO	PAG0 output channel
			TXD1	O	UART1 data output pin
			RXD1	I	UART1 data input pin
			TXD0	O	UART0 data output pin
			SDA0	I/O	I2C0 data input/output pin
			SPI0_CLK	I/O	SPI0 clock input/output pin
			CCP0A	I/O	CCP0 input capture/PWM output A pin
			BKIN	I	EPWM brake input
			EPWM3	O	EPWM output channel 3
12	8	12	P35	I/O	General input/output pin
			AN23	AI	ADC analog channel23
			C1N	AI	ACMP1 negative input channel
			A10	AO	PAG1 output channel
			TXD1	O	UART1 data output pin
			RXD1	I	UART1 data input pin
			RTS0	O	UART0 request to send pin
			SCL0	I/O	SPI0 clock input/output pin
			SPI0_SS	I/O	SPI0 slave select pin
			CCP0B	I/O	CCP0 input capture/PWM output B pin
			EPWM5	O	EPWM output channel 5
			CLKO	O	System clock output pin
13	9	13	P36	I/O	General input/output pin
			AN24	AI	ADC analog channel 23
			C0P3	AI	ACMP0 positive input channel 3
			ECAP03	I	ACMP0 positive input channel 3as input capture
			A0P0	AI	PAG0 positive input channel 0
			TXD1	O	UART1 data output pin
			RXD1	I	UART1 data input pin
			CCP1A	I/O	CCP1 input capture/PWM output A pin
			EPWM0	O	EPWM output channel 0
			CLKO	O	System clock output pin
14	10	14	P16	I/O	General input/output pin
			AN11	AI	ADC analog channel11
			OP1_O	AO	OPA1 output channel
			TXD1	O	UART1 data output pin
			RXD1	I	UART1 data input pin
			RXD0	I	UART0 data input pin
			SCL0	I/O	I2C0 clock input/output pin
			CTS0	I	UART0 clear to send pin
			CCP0B	I/O	CCP0 input capture/PWM output B pin
			EPWM2	O	EPWM output channel2

Pin number			pin name	pin type	description
5533/5533E		5536			
LQFP48	QFN40	LQFP48			
15	11	15	P17	I/O	General input/output pin
			AN12	AI	ADC analog channel12
			OP1_N	AI	OPA1 negative input
			TXD1	O	UART1 data output pin
			RXD1	I	UART1 data input pin
			TXD0	O	UART0 data output pin
			SDA0	I/O	I2C0 data input/output pin
			RTS0	O	UART0 request to send pin
			CCP1A	I/O	CCP1 input capture/PWM output A pin
EPWM4	O	EPWM output channel4			
16	12	16	P21	I/O	General input/output pin
			AN13	AI	ADC analog channel13
			OP1_P	AI	OPA1 positive input
			TXD1	O	UART1 data output pin
			RXD1	I	UART1 data input pin
			RXD0	I	UART0 data input pin
			SCL0	I/O	I2C0 clock input/output pin
			CCP1B	I/O	CCP1 input capture/PWM output B pin
			BKIN	I	EPWM brake input
EPWM5	O	EPWM output channel5			
17	13	17	P22	I/O	general input/output pin
			AN14	AI	ADC analog channel 14
			TXD1	O	UART1 data output pin
			RXD1	I	UART1 data input pin
			TXD0	O	UART0 data output pin
			SCL0	I/O	I2C0 clock input/output pin
			CTS1	I	UART0 clear to send pin
			CCP0A	I/O	CCP0 input capture/PWM output A pin
			EPWM0	O	EPWM output channel 0
SDA0	I/O	I2C0 data input/output pin			
18	14	18	P23	I/O	General input/output pin
			AN15	AI	ADC analog channel15
			OP0_O	AO	OPA0 output channel
			TXD1	O	UART1 data output pin
			RXD1	I	UART1 data input pin
			SDA0	I/O	I2C0 data input/output pin
			RTS1	O	UART1 request to send pin
			CCP0B	I/O	CCP0 input capture/PWM output B pin
			EPWM1	O	EPWM output channel1
19	15	19	P24	I/O	General input/output pin
			AN16	AI	ADC analog channel16
			OP0_N	AI	OPA0 negative input channel
			TXD1	O	UART1 data output pin
			RXD1	I	UART1 data input pin
			SDA0	I/O	I2C0 data input/output pin
			CCP1A	I/O	CCP1 input capture/PWM output A pin

Pin number			pin name	pin type	description
5533/5533E		5536			
LQFP48	QFN40	LQFP48			
			EPWM2	O	EPWM output channel2
20	16	20	P25	I/O	General input/output pin
			AN17	AI	ADC analog channel17
			OP0_P	AI	OPA0 positive input channel
			TXD1	O	UART1 data output pin
			RXD1	I	UART1 data input pin
			SCL0	I/O	I2C0 clock input/output pin
			SPI0_SS	I/O	SPI0 slave select pin
			CCP1B	I/O	CCP1 input capture/PWM output B pin
			EPWM3	O	EPWM output channel3
			C1_O	O	ACMP1 output channel
21	17	21	P26	I/O	General input/output pin
			AN18	AI	ADC analog channel 18
			TXD1	O	UART1 data output pin
			RXD1	I	UART1 data input pin
			SPI0_CLK	I/O	SPI0 clock input/output pin
			CCP0A	I/O	CCP0 input capture/PWM output A pin
			EPWM4	O	EPWM output channel 4
			C0_O	O	ACMP0 output channel
22	18	22	P46	I/O	General input/output pin
			AN28	AI	ADC analog channel 28
			TXD1	O	UART1 data output pin
			RXD1	I	UART1 data input pin
			SPI0_MISO	I/O	SPI0 master input/slave output pin
			CCP1A	I/O	CCP1 input capture/PWM output A pin
			BKIN	I	EPWM brake input
			EPWM2	O	EPWM output channel2
23	19	23	PGND	P	Internal power ground pin
24	20	24	GVDD	P	Internal generated power supply pin
25	21	25	GL3	O	3 phase low side gate driver output pin
26	22	26	GL2	O	2 phase low side gate driver output pin
27	23	27	GL1	O	1 phase low side gate driver output pin
28	24	28	GHS3	P	3 phase floating high side pin
29	25	29	GH3	O	3 phase high side gate driver output pin
30	26	30	BOST3	P	3 phase high side bootstrap pin
31	27	31	GHS2	P	2 phase high side floating pin
32	28	32	GH2	O	2 phase high side gate driver output pin
33	29	33	BOST2	P	2 phase high side bootstrap pin
34	30	34	GHS1	P	1 phase high side floating pin
35	31	35	GH1	O	1 phase high side gate driver output pin
36	32	36	BOST1	P	1 phase high side bootstrap pin
40	38	40	VSS	P	Voltage source supply(ground)
41	33	41	P00	I/O	General input/output pin
			AN0	AI	ADC analog channel 0
			TXD1	O	UART1 data output pin
			RXD1	I	UART1 data input pin

Pin number			pin name	pin type	description
5533/5533E		5536			
LQFP48	QFN40	LQFP48			
			TXD0	O	UART0 transmit data output pin
			CTS0	I	UART0 clear to send pin
			SPI0_CLK	I/O	SPI0 clock input/output pin
			CCP0A	I/O	PWM0 input capture/PWM output A pin
			EPWM2	O	EPWM output channel2
			SWDCLK	I	SWD programming, debugging clock input pin
42	34	42	P40	I/O	General input/output pin
			AN25	AI	ADC analog input channel 25
			TXD1	O	UART1 data output pin
			RXD1	I	UART1 data input pin
			CCP1B	I/O	CCP1 input capture/PWM output B pin
			EPWM1	O	EPWM output channel1
			SWDDAT	I/O	SWD programming, debugging data input/output pin
43	35	43	VDD	P	Power supply
44	36	44	P10	I/O	General input/output pin
			AN6	AI	ADC analog input channel 6
			TXD1	O	UART1 data output pin
			RXD1	I	UART1 data input pin
			TXD0	O	UART0 data output pin
			NRST	I	External reset pin
			CCP0A	I/O	CCP0 input capture/PWM output A pin
			EPWM1	O	EPWM output channel1
			CTS1	I	UART1 clear to send pin
45	37	45	P12	I/O	General input/output pin
			AN7	AI	ADC analog input pin7
			A1P0	AI	PAG1 positive input channel 0
			TXD1	O	UART1 data output pin
			RXD1	I	UART1 data input pin
			RXD0	I	UART0 data input pin
			SDA0	I/O	I2C0 data input/output pin
			SPI0_CLK	I/O	SPI0 clock input/output pin
			CCP1B	I/O	CCP1 input capture/PWM output B pin
			EPWM0	O	EPWM output channel 0
			RTS1	O	UART1 request to send pin

3.3 GPIO Characteristic

Various function sharing of pin. Each I/O interface can be configured as the corresponding digital or analog function. I/O as a general purpose GPIO interface has the following characteristics:

- It can be configured as normal input, pull-up input, pull-down input, push-pull output, leakage opening output without pull-up.
- Configurable high level, low level, rising edge, falling edge, double edge trigger interrupt.
- Configurable high level, low level, rising edge, falling edge to wake up the chip in sleep/deep sleep.
- Configurable tow levels of I/O speed.
- Configurable two levels of output current.

3.4 Pin Function List

Function symbol									
	CONFIG	0	1	2	3	4	5	6	7
P00	-	GPIO	Note ⁽³⁾	TXD0	CTS0	SPI0_CLK	CCP0A	EPWM2	SWDCLK ⁽⁵⁾
P01	-	GPIO	ANA	RXD0	RTS0	SPI0_SS	CCP0B	EPWM0	ADET
P04	-	GPIO	ANA	-	CTS1	SPI0_SS	CCP0A	EPWM1	SPI0_CLK
P05	BOOT	GPIO	ANA	-	RTS1	SPI0_MOSI	CCP0B	EPWM2	ADET
P06	-	GPIO	ANA	-	SDA0	SPI0_MISO	CCP1A	EPWM3	CTS1
P07	-	GPIO	ANA	-	SCL0	SPI0_CLK	CCP1B	EPWM4	-
P10	NRST	GPIO	ANA	TXD0	-	-	CCP0A	EPWM1	CTS1
P12	-	GPIO	ANA	RXD0	SDA0	SPI0_CLK	CCP1B	EPWM0	RTS1
P13	-	GPIO	ANA	TXD0	SCL0	SPI0_MISO	CCP1A	EPWM1	-
P14	-	GPIO	ANA	-	SDA0	SPI0_MOSI	CCP0A	EPWM4	-
P15	-	GPIO	ANA	-	SCL0	SPI0_SS	CCP0A	EPWM5	-
P16	-	GPIO	Note ⁽³⁾	RXD0	SCL0	CTS0	CCP0B	EPWM2	ANA ⁽³⁾
P17	-	GPIO	ANA	TXD0	SDA0	RTS0	CCP1A	EPWM4	-
P21	-	GPIO	ANA	RXD0	SCL0	-	CCP1B	EPWM5	BKIN
P22	-	GPIO	ANA	TXD0	SCL0	CTS1	CCP0A	EPWM0	SDA0
P23	-	GPIO	ANA	-	SDA0	RTS1	CCP0B	EPWM1	
P24	-	GPIO	ANA	-	SDA0	-	CCP1A	EPWM2	
P25	-	GPIO	ANA	-	SCL0	SPI0_SS	CCP1B	EPWM3	C1_O
P26	-	GPIO	ANA	-	-	SPI0_CLK	CCP0A	EPWM4	C0_O
P30	-	GPIO	ANA	RXD0	-	SPI0_CLK	CCP0B	EPWM0	ADET
P31	-	GPIO	ANA	CTS0	SCL0	SPI0_MISO	CCP1A	EPWM4	BKIN
P32	-	GPIO	ANA	RXD0	SDA0	SPI0_MOSI	CCP1B	EPWM1	BKIN
P34	-	GPIO	ANA	TXD0	SDA0	SPI0_CLK	CCP0A	EPWM3	BKIN
P35	-	GPIO	ANA	RTS0	SCL0	SPI0_SS	CCP0B	EPWM5	CLKO
P36	-	GPIO	ANA	-	-	CLKO	CCP1A	EPWM0	-
P40	-	GPIO	ANA	-	-	-	CCP1B	EPWM1	SWDDAT ⁽⁵⁾
P43	NRST	GPIO	ANA	-	-	-	CCP0A	EPWM2	-
P44	NRST	GPIO	ANA	TXD0	-	-	CCP0B	EPWM1	-
P46	-	GPIO	ANA	BKIN	-	SPI0_MISO	CCP1A	EPWM2	-
P47	-	GPIO	ANA	-	RTS1	SPI0_MOSI	CCP1B	EPWM5	-

Cont'd (TXD1 and RXD1 can be configured with any interface)

Function symbol					Function symbol				
		8	9	GPIO	ANA(multiple analog functions can be used at the same time)				
PIN	Priority	UART1	UART1	ECAP	ADC	ACMP	PGA	OP	
P00	Max	TXD1	RXD1	-	AN0 ⁽³⁾	-	-	-	
P01				-	AN1	-	-	-	
P04				-	AN2	-	-	-	
P05				-	AN3	-	-	-	
P06				-	AN4	-	-	-	
P07				-	AN5	-	-	-	
P10				-	AN6	-	-	-	
P12				-	AN7	-	-	A1P0	-
P13				↓	ECAP00	AN8	C0P0	-	-
P14					ECAP01	AN9	C0P1	-	-
P15				ECAP02	AN10	C0P2	A1P1	-	
P16				-	AN11 ⁽³⁾	-	-	-	OP1_O ⁽³⁾
P17				-	AN12	-	-	-	OP1_N
P21				-	AN13	-	-	-	OP1_P
P22				-	AN14	-	-	-	
P23				-	AN15	-	-	-	OP0_O
P24				-	AN16	-	-	-	OP0_N
P25	-	AN17	-	-	-	OP0_P			
P26	-	AN18	-	-	-	-			
P30	↓	ECAP13	AN19	C1P3	A1P2	-			
P31		ECAP10	AN20	C1P0	A0P2	-			
P32		ECAP11	AN21	C1P1	A0P1	-			
P34		ECAP12	AN22	C1P2	A0O	-			
P35		-	AN23	C1N	A1O	-			
P36		ECAP03	AN24	C0P3	A0P0	-			
P40		-	AN25	-	-	-	-		
P43		-	AN26	C0N	A0P3	-			
P44		-	AN27	-	A1P3	-			
P46		-	AN28	-	-	-	-		
P47	min	-	-	-	-	-			

Note :

- (1) When configured as 0, it is GPIO and its Schmitt input remains open (include when the state is output).
When configured as 1, GPIO functions, including output, Schmitt input, pull-up/down are all closed.
- (2) When configured as digital function, analog function is still available. For example, when configure P13 as GPIO and use ECAP function, comparator C0P0 function can also be used at the same time.
- (3) When only using the analog function, it is recommended to set the configuration to 1, turn off the digital circuit to reduce power consumption. When P00 using the analog function, the configuration must be set to GPIO and input mode. The configuration of P16 must be set to 7 when using the analog function.
- (4) The port supports multiple analog functions to be used simultaneously. For example, P25 can be used for both operational amplifier (op-amp) function and AD channel function at the same time.
- (5) SWD(P00/P40) has both simulation and programming functions.

4. Summary of Features

4.1 ARM Cortex-M0

Cortex[®]-M0 is a configurable 32-bit RISC processor with multi-level pipeline. It contains a AMBA AHB-Lite interface which includes NVIC tools and has choice of configurable hardware. This processor can run Thumb instructions and it is compatible with other Cortex[®]-M processors. It has 2 working modes—Thread mode and Handler mod. When exception happens, system enters Handler mode and exception return is only carried out at Handler mode. After system reset or exception return, the processor can enter Thread mode.

4.2 Memory

4.2.1 Program Storage (Flash)

Program storage divided into 2 modes : APROM and BOOT. It is able to choose to boot from APROM or BOOT when power on.

Different products have different memory space. The max. space is 32KB

BOOT has max. space of 4KB.

CMS32M53xx/CMS32M55xx can configure the size of BOOT as follows:

32K(program storage)				
Address space distribution methods	APROM		BOOT	
Method 0	32K	0000H-7FFFH	-	-
Method 1	31K	0000H-7BFFFH	1K	7C00H-7FFFH
Method 2	30K	0000H-77FFFH	2K	7800H-7FFFH
Method 3	28K	0000H-6FFFH	4K	7000H-7FFFH

4.2.2 Non-volatile data memory (Data Flash)

It has memory of 1KB with 2 disk sectors. It is used to store and preserve the data after system shuts down.

4.2.3 Data memory (SRAM)

It has max. memory of 8KB. Every 2KB and be configured to be write-protected after the first 2KB.

4.3 Interrupt Control

Cortex[®]-M0 CPU provides a Nested Vector Interrupt Control (NVIC) to handle interrupts. It supports following features:

- Supports nested vector interrupt.
- Auto-save and restore the state of processor.
- Dynamic priority.
- Simplify and re-assure interrupt time.

System provides multiple external interrupt source, which include GPIO0, GPIO1, GPIO2, GPIO3, GPIO4, CCP, WWDT, EPWM, ADC0, ADC1, ACMP, UART0, UART1, TIMER0, TIMER1, WDT, I2C, SPI and SYS_CHK. The real number of source of interrupts depends on the actual products. Each interrupt supports 4 levels of interrupt priority. The highest priority is 0 and the lowest is 3. The default priority is 0.

4.4 Clock Control

Clock controller provides the entire chip with the source of clock which includes system clock and clocks for all external devices. This controller has separated clock switch, clock source choice and frequency divider to choose different clock. It is also capable to output clock through I/O interfaces.

There are 2 different clock sources :

- Internal high-speed clock HSI (48MHz/64MHz).
- Internal low-speed clock LSI (40KHz).

Clock output can be chosen from the following :

- AHB clock AHBCLK.
- Internal high-speed clock HSI.

4.5 Power Management

4.5.1 Working Mode

The system has 3 different working modes to accommodate different power consumption needs:

- normal mode : MCU works normally, peripherals work normally, LDO enabled.
- sleep mode : MCU in sleep mode, CPU stops, peripherals work normally, LDO enabled.
- deep sleep mode : MCU in deep sleep mode, CPU stops, only WDT works, LDO enabled.

4.5.2 Low-voltage Reset (LVR)

This series of products contains LVR. When the voltage of power source is lower than the pre-defined value, the system resets.

3 choices of low voltage detection voltage : 1.9V/2.1V/2.6V.

4.5.3 Low-voltage Detect (LVD)

This series of products contains LVD. It compares the voltage of the power source with the pre-defined value. If the power source has lower voltage, then it generates interrupt request signal.

6 choices of pre-defined values : 3.7V/3.0V/2.7V/2.4V/2.2V/2.0V.

4.6 Timer

4.6.1 System Timer (SysTick)

Cortex®-M0 has a built-in system timer, SysTick. SysTick provides a simple register which is able to perform 24-bit clear on write, count down and autoloading default settings. This SysTick can be used for RTOS or peripherals for simple timer.

4.6.2 Watchdog Timer (WDT)

WDT is a 32-bit countdown timer which has a 40KHz clock source. When system enters an unknown state WDT is used to reset the system to avoid any infinite loop. WDT supports following features :

- Count clock can choose from 1, 16, 256 frequency division.
- WDT can rest system.
- WDT interrupt supported.
- WDT can resume the system from sleep /deep sleep mode.

4.6.3 Windowed Watchdog Timer (WWDT)

WWDT is a 6-bit countdown timer. WWDT is used to reset the system when entering a specific windowed period to prevent programs from running out of control. WWDT supports following features:

- Configurable 6-bit value for comparing windows.
- Count clock can choose from 14 different frequency division ratio.
- Generate interrupt when countdown value equals to the window-comparing value.
- Load data and generate system reset when countdown value is greater than window-comparing value.
- Reset system when countdown to 0

4.6.4 General Timer (TIMER0/1)

This series of products contains 2 programmable 32/16-bit counter(countdown) to provide user with convenient counting application. TIMER0 and TIMER1 supports following features :

- Count clock can choose from 1, 16, 256 frequency division.
- 3 operating modes: single-triggered, periodic counting, continuous counting.
- Support delay loading of initial value of counter
- Generate interrupt when countdown to 0
- Resume sleep mode from interrupt.

4.7 Enhanced Digital Peripherals

4.7.1 Cyclic Redundancy Check (CRC)

CRC is a commonly used error-detecting code. The main feature is that any choice of length of information data and verification data is possible. CRC verification unit generates polynomial ' $X^{16}+X^{12}+X^5+1$ '(CRC-16-CCITT). The data that needs to be checked is selected from programs, therefore this module is not only used in program flash space but many other places.

4.7.2 Hardware Divider (HWDIV)

This series of products contains a 32bit/32bit hardware divider with the following features :

- Support division of sign/unsigned number.
- Contains indicator when divide 0.
- Quotient and remainder have 32-bit bit width.
- Write on divisor register to start division calculation.
- 6 HCLK clock for calculation

4.7.3 Capture/Compare/Pulse Width Modulation Modules (CCP0/1)

This series of products contains 2 sets of CCP modules: CCP0/CCP1. Each CCP corresponds to A/B channels. CCP modules support PWM output, capture mode 0, capture mode 1, interrupt.

1) PWM output supports following features :

- A, B channels of CCP0 share a periodic register. A, B channels of CCP1 share a periodic register.
- Can configure duty cycle of A, B channels' output separately.
- Max. 4 output of PWM.
- Configurable output polarity.

2) capture mode 0 supports following features :

- CCP0 can choose from A or B as external input signal.
- CCP1 can choose from A or B as external input signal.
- 4 methods of capture:
 - a) software initiated counting, rising edge capture;
 - b) software initiated capture, falling edge capture;
 - c) rising edge counting, falling edge capture;
 - d) falling edge capture, rising edge capture.

3) capture mode 1 supports following features :

- Only CCP1 has capture mode 1.
- CAP0, CAP1, CAP2, CAP3, altogether 4 capture channels, each capture channel has 4 bits to choose different inputs.
- Can choose register triggered software capture mode.
- Can choose rising edge, falling edge and double edge of external signal for capture mode.
- Support CCP1 capture trigger CCP0 counter load enabled.

- 4) CCP has following interrupts :
- PWM interrupt.
 - Capture mode 0 interrupt.
 - CAP0, CAP1, CAP2, CAP3 interrupts in capture mode 1.
 - Counter overflow interrupt.

4.7.4 Enhanced PWM (EPWM)

Enhanced PWM module has 6 PWM generators. Period and duty cycle can be configured separately. EPWM supports following features:

- Support single/continuous output of waveform.
- Support 4 control modes: individual/complementary/synchronous/grouped.
- Counter clock choices: 1, 2, 4, 8, 16 frequency division.
- Support 2 counting modes: edge-aligned/center-aligned.
- Support 4 methods of load updates.
- Support dead-time insertion.
- Configurable output polarity.
- Support periodic, up-comparison, down-comparison and zero interrupt.

4.8 Communication Modules

4.8.1 Universal Asynchronous Receiver-Transmitter (UART0/1)

This series of products contain 2 interfaces: UART0 and UART1. UART has following characteristics :

- Full duplex, asynchronous communication.
- Register structure satisfy 16550 industrial standards.
- Separated 16 byte transmit/receive FIFO.
- Support hardware auto flow control (CTS, RTS.).
- Support software flow control (XOFF, XON).
- Choice of level of receive data buffer.
- Data length can be set to 5-8.
- Stop bit can be set to 1-bit, 1.5-bit or 2-bit.
- Check bit can be set to odd/even/none/fixed.

4.8.2 I²C Inter-Integrated Circuit (I²C)

This series of products contains a 2-wire serial control, I²C. It supports following features:

- Standard I²C compatible of bus interface.
- Support master /slave mode. Bidirectional data transfer between master and slave.
- Arbitration during multi master data transfer to avoid serial data damage on the bus.
- Bus with serial synchronous clock to achieve different transfer speed between different devices.
- Programmable clock for transfer speed control.
- Support 7/ 10bit address mode.
- Support multi address identification.

4.8.3 Serial Peripheral Interface (SSP/SPI)

This series of products contains 1 full duplex and synchronous SSP/SPI. SSP/SPI supports following features :

- Compatible of: SPI from Motorola, 4 wire SSI from TI and Microwire bus from NS.
- Support master or slave mode.
- Configurable length of send bit.
- Configurable clock polarity and phase.
- Programmable clock speed control.
- Provides eight 16-bit transmit/receive FIFO.

4.9 Analog Module

4.9.1 Low Speed ADC (ADC0)

This series of products contains a 12-bit successive approximation ADC (ADC0) which supports single/continuous converting modes. ADC0 supports the following features :

- Analog input voltage range : AVSS(VSS) ~ AVDD(VDD).
- Max. sampling rate: 100Ksps.
- 24 single-ended analog input channels.
- Single conversion time of $18.5 \cdot T_{ADCK}$.
- Single mode: carry a A/D convert to a selected channel.
- Continuous mode: carry A/D convert for all selected channels.
- Support external input signal to trigger ADC.
- Generate interrupt after finishing converting.
- Built-in ADC result comparator.
- ADC results from every channel are stored to respective data registers.
- Channel 30 can test internal analog voltage signal (including OP0/1 output, PGA0/1 output, built in 1.2V reference voltage)

4.9.2 Fast ADC (ADC1)

This series of products contains a 12-bit successive approximation ADC (ADC1) which supports single/continuous converting modes. The fastest conversion time for single mode ADC is about 0.8us. The fastest total conversion time for continuity mode of any of the 4 channel ADC is about 3.2us, 12.8us for 16 channel ADC. ADC1 supports following features :

- Analog input voltage range : AVSS(VSS) ~ AVDD(VDD).
- Max. sampling rate : 1.2Msps.
- 24 single-ended analog input channels.
- Single conversion time of : $23 \cdot T_{ADCK}$ (sampling time set to $10.5 \cdot T_{ADCK}$).
- Single mode: carry a A/D convert to a selected channel.
- Continuous mode: carry A/D convert for all selected channels.
- Support external input signal to trigger ADC
- Generate interrupt after finishing converting.
- Built-in ADC result comparator.
- ADC results from every channel are stored to respective data registers.
- Channel 30 can test internal analog voltage signal (including OP0/1 output, PGA0/1 output, built in 1.2V reference voltage)

4.9.3 Analog Comparator (ACMP0/1)

This series of products contains 2 analog comparators, ACMP0 and ACMP1. ACMP0/1 supports following features :

- Analog input voltage range : 0~(VDD-1.5V).
- Support hysteresis voltage choice (10mV/20mV/60mV-typical value).
- Positive end can choose multiple input interfaces.
- Negative end can choose input interface or internal reference voltage.
- 16 levels of internal reference voltage division.
- Support output filter with 11 choices of filters.
- Support change in output to generate interrupt.

4.9.4 Operational Amplifier (OP0/1)

This series of product contains OP0 and OP1 which supports following features :

- Can configure to operational amplifier mode or comparator mode.
- Measure output through ADC.

4.9.5 Programmable Gain Amplifier (PGA0/1)

This series of products contains 2 programmable gain amplifier PGA0 and PGA1 which supports the following features

- Adjustable gain(4X/8X/10X/12X/14X/16X/32X).
- Measure output through ADC.

4.10 Memory Control Module

FLASH memory includes program memory (APROM/BOOT) and non-volatile data memory (Data FLASH). It is possible to read/write through relative special function (SFR) registers to achieve IAP function. FLASH memory supports the following :

- Byte reading
- Byte writing
- Page erase
- FLASH CRC.

4.11 Security

4.11.1 Unique Identifier (UID)

Every chip has 96-bit UID which is set during manufacture. Users can only read but not modify.

4.11.2 User Unique Identifier (USRUID)

Every chip has a 128-bit USRID, which includes 96-bit user-configurable ID and a 32-bit fixed ID. This USRUID cannot be accessed from memory module. USRUID can be used as key in during encryption of some applications. Users can set protection through checking this key.

4.11.3 Protection of Code for Programs

Support protection of codes through partition and distribution. In APROM space, every 2Kbytes is a chunk. In BOOT space, every 1Kbytes is a chunk. Users can configure protection state from config registers.

4.11.4 Program CRC

Support hardware to calculate CRC verification code. Choice of check interval is allowed. CRC verification code is generated from polynomial CRC-16-CCITT ' $X^{16}+X^{12}+X^5+1$ '.

4.11.5 General CRC

Use general CRC to check the correctness of program or transferred data. Verification code for general CRC module is also generated from polynomial ' $X^{16}+X^{12}+X^5+1$ '.

4.11.6 Unauthorized Read/Write Detection of Memory

If authorized memory address in ARM MCU is accessed, bus will return an error signal to provide better program error detection.

4.11.7 SRAM Protection

Internal SRAM is write-protected and can be configured to distributed storage. Write-protection does not affect reading process. Relative functions can be set from system register SRAMLOCK.

4.11.8 SFR Protection

SFR in key modules has protection state. Reading/writing is disabled under the protection state.

4.11.9 ADC0/1 Test

Check whether ADC is working properly through converting ADC's positive reference voltage, negative reference voltage, analog input channel, internal reference voltage.

4.11.10 GPIO Pin Electrical Level Detection

It is possible to read pin's electrical level through GPIO->DI when interface is configured as output or input under GPIO.

5. User Configuration

User configuration area is a 128-word (512 bytes) storage area allocated in FLASH. Following features can be achieved through setting the registers:

- LVR reset voltage
- Power-On reset bootup space (APROM/BOOT) .
- User programs, User UID, Data-Flash encryption control.
- Power-On WDT enable control, initial loading value.
- SWD debug function.
- External reset function and pin distribution.

6. Electrical Characteristics

6.1 MCU Absolute Maximum Ratings

Symbol	Parameter	Min.	Max.	Unit
$V_{DD}-V_{SS}$	voltage	-0.3	5.8	V
V_{IN}	Input voltage	$V_{SS}-0.3$	$V_{DD}+0.3$	V
T_A	Operating temperature	-40	+105	°C
T_{ST}	storage temperature	-55	+150	°C
I_{DD}	VDD maximum input current	-	120	mA
I_{SS}	VSS maximum output current	-	120	mA
I_{IO}	Single IO maximum sink current	-	50	mA
	Single IO maximum output current	-	40	mA
	All IO maximum sink current	-	100	mA
	All IO maximum output current	-	100	mA

6.2 D.C Electrical Characteristics

($V_{DD}-V_{SS}=2.1\sim 5.5V, T_A=25^{\circ}C$)

Symbol	Parameter	Conditions	Min.	Typ.	Max.	Unit
V_{DD}	Voltage	HCLK=64MHz	2.1	-	5.5	V
I_{DD1}	operating current	HCLK=64MHz, HSI=64MHz, ALL APBCLK OFF, $V_{DD}=5.0V$	-	12	-	mA
I_{DD2}		HCLK=64MHz, HSI=64MHz, ALL APBCLK OFF, $V_{DD}=3.3V$	-	12	-	mA
I_{DD3}		HCLK=48MHz, HSI=48MHz, ALL APBCLK OFF, $V_{DD}=5.0V$	-	9	-	mA
I_{DD4}		HCLK=48MHz, HSI=48MHz, ALL APBCLK OFF, $V_{DD}=3.3V$	-	9	-	mA
I_{DD5}		HCLK=40KHz, LSI=40KHz, ALL APBCLK OFF, $V_{DD}=5V$	-	0.25	-	mA
I_{DD6}		HCLK=40KHz, LSI=40KHz, ALL APBCLK OFF, $V_{DD}=3.3V$	-	0.25	-	mA
I_{DEEP_SLEEP}		Deep sleep mode current	LDO on, $V_{DD}=5V$	-	200	-
V_{IL}	Input low level	-	VSS	-	0.3VDD	V
V_{IH}	Input high level	-	0.7VDD	-	VDD	V
I_{OL1}	Low-level output current	$V_{DD}=5V$ GPIOxDR[n]=0 VIO=1.5V	-	-	50	mA
I_{OL2}		$V_{DD}=5V$ GPIOxDR[n]=1 VIO=1.5V	-	-	25	mA
I_{OH1}	High-level output current	$V_{DD}=5V$ GPIOxDR[n]=0 VIO=3.5V	-	-	40	mA
I_{OH2}		$V_{DD}=5V$ GPIOxDR[n]=1 VIO=3.5V	-	-	20	mA
R_{UP}	Pull-up resistor	-	-	33	-	K Ω
R_D	Pull-down resistor	$T_A=25^{\circ}C, V_{DD}=5V, V_{IO}=0.3VDD$	-	33	-	K Ω
F_{AHBCLK}	AHB clock	-	-	-	64	MHz
F_{APBCLK}	APB clock	-	-	-	64	MHz

6.3 MCU A.C. Electrical Characteristic

6.3.1 Power-on Reset Time

Symbol	Parameter	Conditions	Min.	Typ.	Max.	Unit
T _{RESET}	Reset time	V _{DD} =5V	-	4.5	-	ms
T _{VDDR}	VDD rise rate	V _{DD} =5V	2	-	-	us/V
T _{VDDF}	VDD fall rate	V _{DD} =5V	2	-	-	us/V

6.3.2 Internal High-speed Oscillator (HSI)

Symbol	Parameter	Min.	Typ.	Max.	Unit
V _{HSI}	Operating voltage	2.1	-	5.5	V
T _A	Operating temperature	-40	-	105	°C
I _{HSI}	operating current V _{DD} =5.0V, T _A =25°C	-	300	-	uA
F _{HSI48M}	T _A =25°C, V _{DD} =5.0V	-	48	-	MHz
	T _A =25°C, V _{DD} =2.1~5.5V	-0.5	-	+0.5	%
	T _A =0°C~85°C, V _{DD} =2.1~5.5V	-1.5	-	+1.0	%
	T _A =-40°C~105°C, V _{DD} =2.1~5.5V	-2.0	-	+1.0	%
F _{HSI64M}	T _A =25°C, V _{DD} =5.0V	-	64	-	MHz
	T _A =25°C, V _{DD} =2.1~5.5V	-0.5	-	+0.5	%
	T _A =0°C~85°C, V _{DD} =2.1~5.5V	-2.0	-	+1.0	%
	T _A =-40°C~105°C, V _{DD} =2.1~5.5V	-2.5	-	+1.0	%

6.3.3 Internal low-speed Oscillator (LSI)

Symbol	Parameter	Min.	Typ.	Max.	Unit
V _{LSI}	Operating voltage	2.1	-	5.5	V
T _A	Operating temperature	-40	-	105	°C
I _{LSI}	operating current V _{DD} =5.0V, T _A =25°C	-	10	-	uA
F _{LSI}	T _A =25°C, V _{DD} =5.0V	-	40	-	KHz
	T _A =25°C, V _{DD} =2.1~5.5V	-20	-	+20	%
	T _A =0°C~85°C, V _{DD} =2.1~5.5V	-28	-	+28	%
	T _A =-40°C~105°C, V _{DD} =2.1~5.5V	-50	-	+50	%

6.3.4 Low Voltage Reset Electrical Parameters (LVR)

Symbol	Parameter	Min.	Typ.	Max.	Unit
V _{LVR1}	Low-voltage detection threshold 1.9V	1.75	1.9	2.05	V
V _{LVR2}	Low-voltage detection threshold 2.1V	1.95	2.1	2.25	V
V _{LVR3}	Low-voltage detection threshold 2.6V	2.45	2.6	2.75	V

6.3.5 Low Voltage Detection Circuit (LVD)

Symbol	Parameter	Min.	Typ.	Max.	Unit
V _{LVD1}	Low-voltage detection threshold 2.0V	1.85	2.0	2.15	V
V _{LVD2}	Low-voltage detection threshold 2.2V	2.05	2.2	2.35	V
V _{LVD3}	Low-voltage detection threshold 2.4V	2.25	2.4	2.55	V
V _{LVD4}	Low-voltage detection threshold 2.7V	2.55	2.7	2.85	V
V _{LVD5}	Low-voltage detection threshold 3.0V	2.85	3.0	3.15	V
V _{LVD6}	Low-voltage detection threshold 3.7V	3.55	3.7	3.85	V

6.4 FLASH Electrical Parameters

Symbol	Parameter	Condition	Min.	Typ.	Max.	Unit
V _F	Flash Operating Voltage	-	2.1	-	5.5	V
T _F	Flash Operating Temperature	-	-40	25	125	°C
N _{ENDURANCE}	Endurance	-	20,000	-	-	Cycle
T _{RET}	Data Retention	25°C	100	-	-	year
T _{ERASE}	Sector Erase Time	-	-	4.7	-	ms
T _{WRITE}	Write Byte Time	-	-	50	-	us
I _{DD1}	Read Current	-	-	-	3.5	mA
I _{DD2}	Program Current	-	-	-	3.5	mA
I _{DD3}	Erase Current	-	-	-	2	mA

6.5 Analog Electrical Characteristics

6.5.1 BANDGAP Electrical Characteristic

VDD=2.1V-5.5V.

Symbol	Parameter	Condition	Min.	Typ.	Max.	Unit
V _{REF}	Internal reference 1.2V	T _A =-40°C ~ 105°C	1.188	1.2	1.212	V

6.5.2 ADC0 Electrical Characteristic

T_A = 25°C.

Symbol	Parameter	Min.	Typ.	Max.	Unit
V _{AVDD}	ADC operating voltage	2.5	-	5.5	V
V _{REF}	Reference voltage	-	V _{AVDD}	-	V
V _{ADI}	Analog signal input	0	-	V _{REF}	V
N _R	Resolution	12			Bit
DNL	Differential non-linearity error (V _{REF} =V _{AVDD} =5V, T _{ADCK} =0.5us)	±4			LSB
INL	Integral non-linearity error (V _{REF} =V _{AVDD} =5V, T _{ADCK} =0.5us)	±5			LSB
T _{ADCK}	ADC clock cycle	0.5	-	32	us
T _{ADC}	ADC conversion time	-	18.5	-	T _{ADCK}
F _s	Sampling rate (V _{REF} =V _{AVDD} =5V)	100			Ksps

Remark: It is guaranteed by the design and not tested in mass production.

6.5.3 ADC1 Electrical Characteristic

T_A = 25°C.

Symbol	Parameter	Min.	Typ.	Max.	Unit
V _{AVDD}	ADC operating voltage	2.5	-	5.5	V
V _{REF}	Reference voltage	-	V _{AVDD}	-	V
V _{ADI}	Analog signal input	0	-	V _{REF}	V
N _R	Resolution	12			Bit
DNL	Differential non-linearity error (T _{ADCK} =0.0625us, T _{ADC} =23 *T _{ADCK})	±4			LSB
INL	Integral non-linearity error (T _{ADCK} =0.0625us, T _{ADC} =23 *T _{ADCK})	±5			LSB
T _{ADCK}	ADC clock cycle	0.0325	-	5.3	us
T _{ADC}	AD conversion time (Sample hold time:10.5*T _{ADC})	-	23	-	T _{ADCK}
F _c	Conversion rate	1.4			Msp
F _s	Sampling rate	1.2			Msp

Remark: It is guaranteed by the design and not tested in mass production.

6.5.4 OP0/1 Electrical Parameter

$T_A = 25^\circ\text{C}$, $V_{\text{SENSE}} = V_{\text{IN}+} - V_{\text{IN}-}$, $V_{\text{DD}} = 5\text{V}$, $V_{\text{IN}+} = 1\text{V}$, Unless otherwise indicated.

Symbol	Parameter	Condition	Min.	Typ.	Max.	Unit
VDD	Operating Voltage	-	2.5	-	5.5	V
I _Q	Quiescent Current	$V_{\text{SENSE}}=0\text{mV}$	-	0.8	1.3	mA
I _{SD}	Shutdown current	-	-	5	-	nA
T _A	Operating temperature	-	-40	25	105	°C
Input Characteristic						
V _{OS}	Input Offset Voltage	No zero adjustment	-	±3.8	-	mV
		After zero adjustment	-	±0.5	-	
V _{CM}	Common-mode Input Range	-40°C~105°C	0	-	VDD-1.5	V
I _B	Input Bias Current	$V_{\text{SENSE}}=0\text{mV}$	-	10	-	pA
I _{OS}	Input offset Current	$V_{\text{SENSE}}=0\text{mV}$	-	10	-	pA
Output Characteristic						
C _{LOAD}	Capacitive load	-	-	30	-	pF
V _{OH}	Maximum output voltage	-40°C~105°C	-	-	VDD-0.3	V
V _{OL}	Minimum output voltage	-40°C~105°C	0.3	-	-	V
Frequency characteristic						
A _{OL}	Open loop gain	-	-	105	-	dB
BW	Bandwidth	$C_{\text{LOAD}}=30\text{pF}$	-	5	-	MHz
PSRR	Power Supply Rejection Ratio	$V_{\text{DD}}=2.5\sim 5.5\text{V}$, $V_{\text{IN}+}=1\text{V}$, $V_{\text{SENSE}}=0\text{mV}$	-	59	-	dB
CMRR	Common Mode Rejection Ratio	$V_{\text{IN}+}=0.3\sim (V_{\text{DD}}-1.5)$ -40°C~105°C	-	110	-	dB
Transient characteristic						
SR	Slew Rate	$C_{\text{LOAD}}=30\text{pF}$	-	±5	-	V/μs
		$R_{\text{LOAD}}=2\text{K}$, $C_{\text{LOAD}}=100\text{pF}$	-	±4	-	V/μs
T _{STB}	Stable Time	-	-	-	1.5	μs

Remark: It is guaranteed by the design and not tested in mass production.

6.5.5 ACMP0/1 Electrical Parameter

$T_A = 25^\circ\text{C}$, $V_{\text{SENSE}} = V_{\text{IN}+} - V_{\text{IN}-}$, $V_{\text{DD}} = 5\text{V}$, $V_{\text{IN}+} = 1\text{V}$, Unless otherwise indicated.

Symbol	Parameter	Condition	Min.	Typ.	Max.	Unit
VDD	Operating Voltage	-	2.1	-	5.5	V
I _Q	Quiescent Current	$V_{\text{SENSE}}=0.1\text{V}$	-	0.3	0.4	mA
I _{SD}	Shutdown current	$V_{\text{SENSE}}=0.1\text{V}$	-	5	-	nA
T _A	Operating temperature	-	-40	25	105	°C
Input Characteristic						
V _{OS}	Input Offset Voltage	No zero adjustment	-	±4.0	-	mV
		After zero adjustment	-	±0.5	-	
V _{CM}	Common-mode Input Range	-40°C~105°C	-0.1	-	VDD-1.5	V
I _B	Input Bias Current	$V_{\text{SENSE}}=0\text{mV}$	-	10	-	pA
I _{OS}	Input offset Current	$V_{\text{SENSE}}=0\text{mV}$	-	10	-	pA
V _{HYS}	Input hysteresis voltage	$V_{\text{DD}}=2.1\sim 5.5\text{V}$, $V_{\text{IN}+}=0.5\text{V}$	-	0 ±10 ±20 ±60	-	mV
Output Characteristic						
V _{OH}	Maximum output voltage	-40°C~105°C	-	-	VDD	V
V _{OL}	Minimum output voltage	-40°C~105°C	0	-	-	V
Frequency characteristic						
A _{OL}	Open loop gain	-	-	85	-	dB
BW	Bandwidth	-	-	120	-	MHz
PSRR	Power Supply Rejection Ratio	$V_{\text{DD}}=2.1\sim 5.5\text{V}$, $V_{\text{IN}+}=1\text{V}$, $V_{\text{SENSE}}=0\text{mV}$	-	80	-	dB
CMRR	Common Mode Rejection Ratio	$V_{\text{DD}}=2.1\sim 5.5\text{V}$, -40°C~105°C	-	90	-	dB
Transient characteristic						
T _{STB}	Stable Time	-	-	-	1.5	μs
T _{PGD}	Response dela	$V_{\text{COM}}=1\text{V}$, $V_{\text{IN}+}= V_{\text{IN}-} \pm 0.1\text{V}$	-	50	100	ns

Remark: It is guaranteed by the design and not tested in mass production.

6.5.6 PGA0/1 Electrical Parameter

$T_A = 25^\circ\text{C}$, $V_{DD} = 5\text{V}$, $V_{IN+} = 0.1\text{V}$, Unless otherwise indicated. (G is the gain multiple).

Symbol	Parameter	Condition	Min.	Typ.	Max.	Unit
VDD	Operating Voltage	-	2.5	-	5.5	V
I _Q	Quiescent Current	V _{OUT} =2V	-	0.9	1.6	mA
I _{SD}	Shutdown current	-	-	10	-	nA
T _A	Operating temperature	-	-40	25	105	°C
Input Characteristic						
V _{OS}	Input Offset Voltage	-	-	±3.0	-	mV
V _{CM}	Common-mode Input Range	-40°C~105°C	0.07*VDD/ G	-	0.93*VDD/ G	V
I _B	Input Bias Current	-	-	10	-	pA
I _{OS}	Input offset Current	-	-	10	-	pA
Output Characteristic						
EG	Gain error	G=4,8	-1	-	1	%
		G=10,12,14,16	-1.5	-	1.5	
		G=32	-2	-	2	
C _{LOAD}	Capacitive load	-	-	10	-	pF
V _{OH}	Maximum output voltage (internal)	-40°C~105°C	-	VDD-0.3	-	V
V _{OL}	Minimum output voltage	-40°C~105°C	-	0.3	-	V
V _{A00} V _{A10}	Test output interface of PGA0/1 (A00, A10)	-40°C~105°C	-	-	3.7	V
Frequency characteristic						
BW	Bandwidth	R _{LOAD} =0.8MΩ, C _{LOAD} =3pF, G=4	-	2	-	MHz
PSRR	Power Supply Rejection Ratio	VDD=2.5~5.5V	-	75	-	dB
CMRR	Common Mode Rejection Ratio	-40°C~105°C	-	80	-	dB
Transient characteristic						
SR	Slew Rate	R _{LOAD} =0.8MΩ, C _{LOAD} =3pF	-	6	-	V/μs
		R _{LOAD} =2KΩ, C _{LOAD} =100pF	-	4	-	V/μs
T _{STB}	Stable Time	-	-	-	2	μs

Remark: It is guaranteed by the design and not tested in mass production.

6.6 GATE DRIVER(6N) Electrical Characteristic (CMS32M5533)

6.6.1 Internal Logic Block Diagram

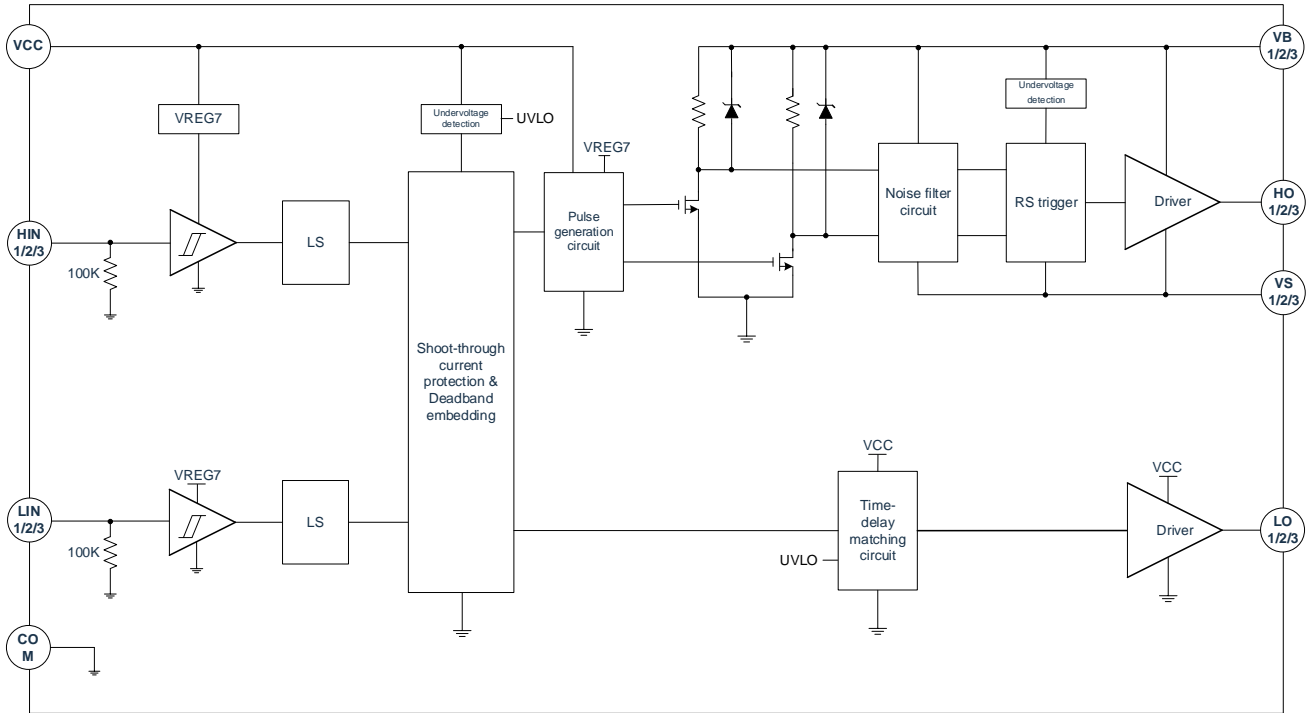

6N pre-driver internal logic block diagram

6.6.2 Static Electrical Characteristic Parameters

(V_{CC-COM}) = (V_B-V_S)=15V. Without other explanation, otherwise the reference temperature is $T_A=25^{\circ}\text{C}$. Input parameters of all channels V_{IN} , T_H , V_I , and I_{IN} on COM pin for reference. Likewise, Output parameters of all low edge driver V_O and I_O on COM pin for reference. However, output parameters of all high edge driver V_O and I_O with their own V_S for reference. V_{CCUV} parameter on COM for reference. V_{BSUV} parameter on V_S for reference.

Symbol	Parameter	Condition	Min	Typical	Max	Unit
Low edge characteristics of power supply						
I_{QVCC1}	Static VCC power supply current	$V_{HIN1,2,3} = V_{LIN1,2,3} = 0$ or 5V, $V_{ENB} = 0$	210	330	450	μA
I_{QVCC2}	Static VCC power supply current in standby mode	$V_{HIN1,2,3} = V_{LIN1,2,3} = 0$ or 5V, $V_{ENB} = 5$	-	46	80	
I_{VCCOP}	Dynamic VCC power supply current	$F_{LIN1,2,3} = 20\text{KHZ}$, $F_{HIN1,2,3} = 20\text{KHZ}$,	-	1500	-	
V_{CCUV+}	VCC power supply under voltage lock positive threshold voltage	-	2.9	4.2	5.5	V
V_{CCUV-}	VCC power supply under voltage lock negative threshold voltage	-	2.5	3.8	5.1	
V_{CCHYS}	VCC power supply under voltage lock magnetic hysteresis voltage	-	-	0.4	-	
High edge floating characteristics of power supply						
V_{BSUV+}	High edge VBS power supply under voltage lock positive threshold voltage	-	2.5	3.8	5.5	V
V_{BSUV-}	High edge VBS power supply under voltage lock negative threshold voltage	-	2.2	3.5	4.8	
$V_{BSUVHYS}$	High edge VBS power supply under voltage lock magnetic hysteresis voltage	-	-	0.3	-	
I_{QBS}	High edge static VBS power supply current	$V_{BS} = 15\text{V}$	25	45	65	μA
I_{LK}	High edge leakage current	$V_B = V_S = 100\text{V}$ $V_{CC} = 0\text{V}$	-	-	10	
Logic input characteristic						
V_{IH}	HIN1,2,3, LIN1,2,3 and ENB=logic "1" voltage	-	2.5	-	-	V
V_{IL}	HIN1,2,3, LIN1,2,3 and ENB logic "0" voltage	-	-	-	0.8	
$V_{IN, TH+}$	Input positive threshold voltage	-	-	1.9	-	
$V_{IN, TH-}$	Input negative threshold voltage	-	-	1.4	-	
I_{IN+}	Logic "1" input bias current	$V_{IN} = 5\text{V}$	-	50	-	μA
I_{IN-}	Logic "0" input bias current	$V_{IN} = 0$	-	0	-	
Characteristics of gate driver						
I_{HO+}	High edge driver output "high" short-circuited current (withdraw)	$V_{HO} = V_S = 0$	-	1.2	-	V
I_{HO-}	High edge driver output "low" short-circuited current (entrance)	$V_{HO} = V_B = 15\text{V}$	-	2.0	-	
I_{LO+}	Low edge driver output "high" short-circuited current (withdraw)	$V_{LO} = 0$	-	1.2	-	
I_{LO-}	Low edge driver output "low" short-circuited current (entrance)	$V_{LO} = V_{CC} = 15\text{V}$	-	2.0	-	
V_{SN}	Negative VS voltage can be allowed when HIN signal is normally transmitted to HO	$V_{BS} = 15\text{V}$	-	-8	-	V

6.6.3 Dynamic Electrical Characteristic Parameters

Without other explanation, otherwise all are (VCC-COM) = (VB-VS)=15V, $V_{S1,2,3}$ =COM, and C_{load} =1nF, the temperature of surrounding environment T_A =25°C.

Symbol	Parameter	condition	Min	Typical	Max	Unit
T_{on}	Turn-on transmission delay	$V_{HIN1,2,3}$ or $V_{LIN1,2,3}$ =5V, $V_{S1,2,3}$ =0	-	120	200	ns
t_{off}	Turn-off transmission delay	$V_{HIN1,2,3}$ or $V_{LIN1,2,3}$ =0, $V_{S1,2,3}$ =0	-	120	200	
t_r	Turn-on rise time	$V_{HIN1,2,3}$ or $V_{LIN1,2,3}$ =5V, $V_{S1,2,3}$ =0	-	37	-	
t_f	Turn-off fall time	$V_{HIN1,2,3}$ or $V_{LIN1,2,3}$ =0, $V_{S1,2,3}$ =0	-	30	-	
DT	Dead time	$V_{HIN1,2,3}$ or $V_{LIN1,2,3}$ =0~5V, No external dead time	300	500	700	
MDT	Six channels dead time match	No external dead time	-	-	50	
MT	Six channels delay match	external dead time > 1000ns	-	-	50	
PM	Output pulse width match	external dead time > 1000ns, PW_{IN} =10 μ s, PM = PW_{OUT} - PW_{IN}	-	-	50	
$T_{FLT, ENB}$	ENB input filtering time width	V_{ENB} =0 ~ 5V	-	450	-	μ s
$T_{off, ENB}$	ENB input "high" to HO/LO turn-off delay	V_{ENB} =5V	-	0.55	-	
$T_{on, ENB}$	ENB input "low" to HO/LO turn-on delay	V_{ENB} =0V	-	6	-	

6.6.4 VS Negative Voltage Curve

The Negative Transient Safe Operating Area (NTSOA) is used to characterize the gate driver's ability to handle transient negative voltages. Negative pulses with amplitudes and pulse widths within the area above the blue line shown in the figure below will allow the gate driver to operate normally. Pulses with excessive amplitude (in the area below the blue line) may cause the gate driver to operate improperly or even be permanently damaged.

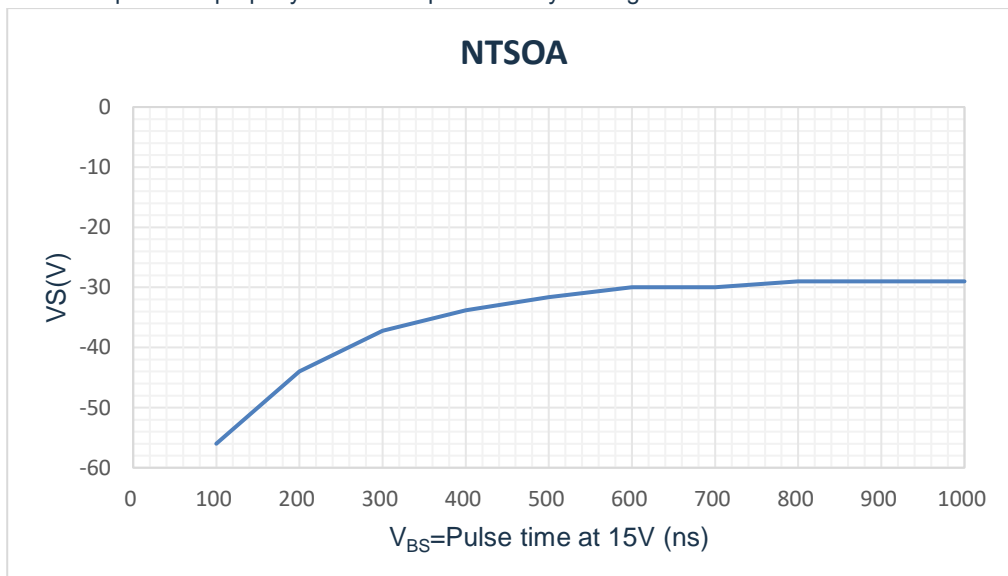

6.7 GATE DRIVER(6N) Electrical Characteristic (CMS32M5533E)

6.7.1 Internal Logic Block Diagram

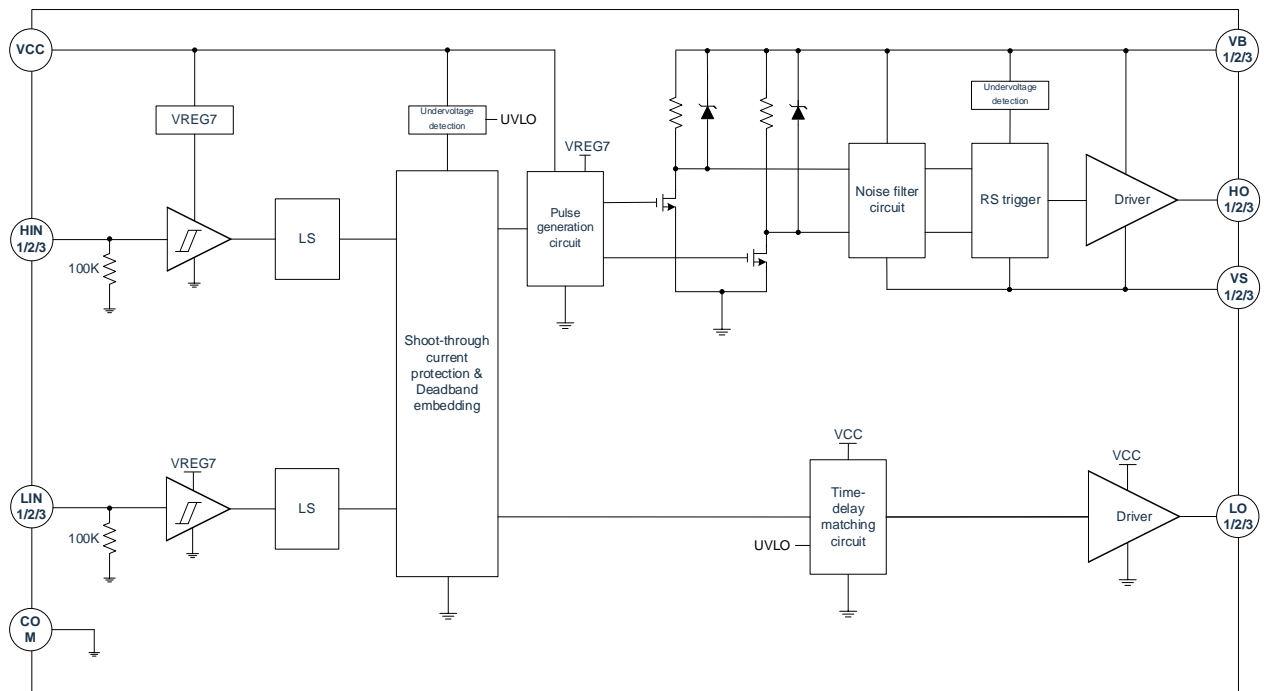

6.7.2 Absolute Maximum Ratings

(Unless otherwise indicated, $T_A=25^{\circ}\text{C}$, GND as a reference point for all pins).

Parameter	Symbol	Min	Max	Unit
High side floating offset absolute voltage	$V_{B1,2,3}$	-0.3	225	V
High side floating offset relative voltage	$V_{S1,2,3}$	$V_{B1,2,3}-25$	$V_{B1,2,3}+0.3$	V
High side output voltage	$V_{HO1,2,3}$	$V_{S1,2,3}-0.3$	$V_{B1,2,3}+0.3$	V
Maximum power supply	VCC	-0.3	25	V
Low side output voltage	$V_{LO1,2,3}$	-0.3	$V_{CC}+0.3$	V
Maximum power supply (HIN1,2,3/LIN1,2,3)	V_{IN}	-0.3	15	V
Maximum voltage slew rate of offset voltage	dVS/dt	-	50	V/ns
Environmental thermal resistance (Note1)	LQFP48	θ_{JA}	52	$^{\circ}\text{C}/\text{W}$
	QFN40		45	
Junction temperature	T_J	-	150	$^{\circ}\text{C}$
Storage temperature	T_s	-55	150	$^{\circ}\text{C}$
Welding temperature of pins (duration 10s)	T_L	-	260	$^{\circ}\text{C}$
ESD (Note2)	V_{ESD}	-	2000	V

注:

- T_A is the ambient temperature at which the circuit operates, θ_{JA} is the thermal resistance of the package, and 150°C is the maximum operating junction temperature of the circuit;
- Human model, 100pF capacitor is discharged through the 1.5K Ω resistor;
- When the working conditions of circuit exceed the range specified by the absolute maximum ratings, it is likely to cause immediate damage to the circuit.

6.8 GATE DRIVER(6N) Electrical Characteristic (CMS32M5536)

6.8.1 Internal Logic Block Diagram

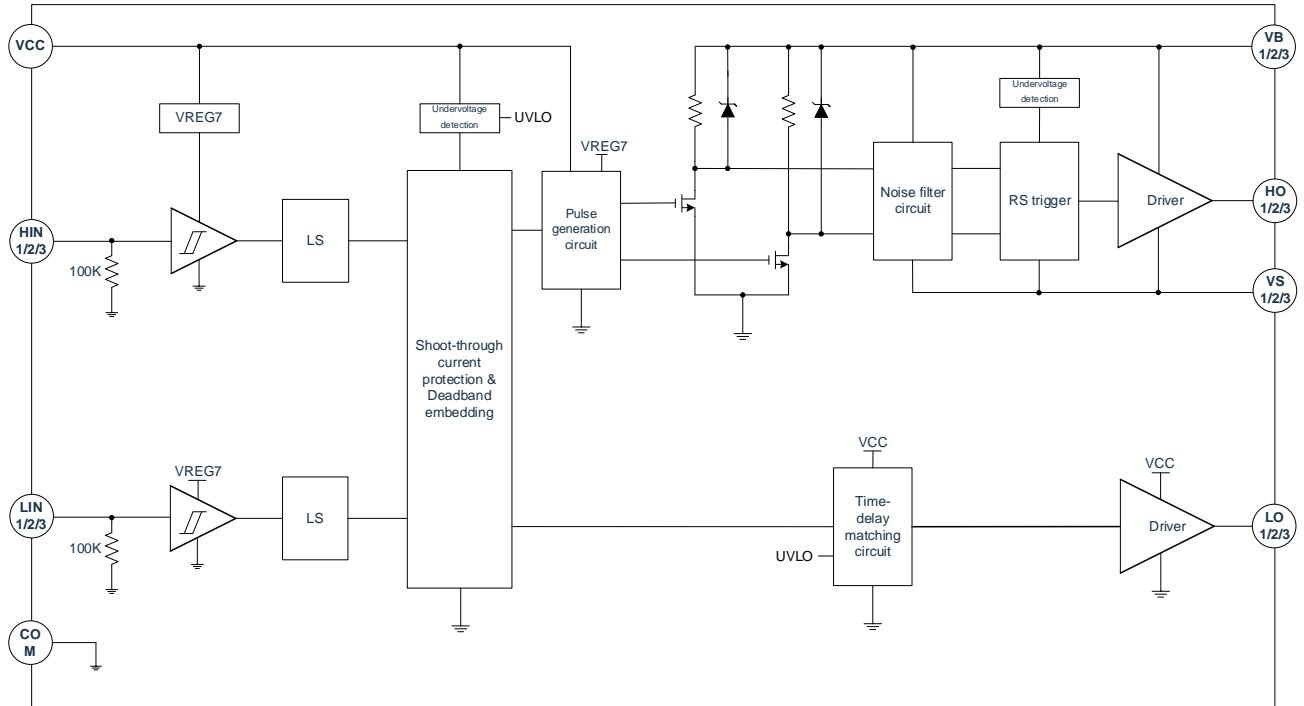

6N pre-driver internal logic block diagram

6.8.2 Absolute Maximum Ratings

(Unless otherwise indicated, $T_A=25^{\circ}\text{C}$, GND as a reference point for all pins).

Parameter	Symbol	Min	Max	Unit
High side floating offset absolute voltage	$V_{B1,2,3}$	-0.3	225	V
High side floating offset relative voltage	$V_{S1,2,3}$	$V_{B1,2,3}-25$	$V_{B1,2,3}+0.3$	V
High side output voltage	$V_{HO1,2,3}$	$V_{S1,2,3}-0.3$	$V_{B1,2,3}+0.3$	V
Maximum power supply	VCC	-0.3	25	V
Low side output voltage	$V_{LO1,2,3}$	-0.3	VCC	V
Maximum power supply (HIN1,2,3/LIN1,2,3)	V_{IN}	-0.3	10	V
Maximum voltage slew rate of offset voltage	dVS/dt	-	50	V/ns
Environmental thermal resistance	θ_{JA}	-	100	$^{\circ}\text{C}/\text{W}$
Junction temperature	T_J	-	150	$^{\circ}\text{C}$
Storage temperature	T_s	-55	150	$^{\circ}\text{C}$
Welding temperature of pins (duration 10s)	T_L	-	260	$^{\circ}\text{C}$
ESD (note 2)	V_{ESD}	-	2000	V

Note:

- 1) T_A is the environmental temperature, θ_{JA} is package thermal resistance, the highest junction temperature for the circuit is 150°C ;
- 2) Human model, 100pF capacitor is discharged through the 1.5K Ω resistor;
- 3) When the working conditions of circuit exceed the range specified by the absolute maximum ratings, it is likely to cause immediate damage to the circuit.

6.8.3 Recommended working conditions

(Unless otherwise indicated, $T_A=25^{\circ}\text{C}$, GND as a reference point for all pins).

Parameter	Symbol	Min	Typical	Max	Unit
High side floating offset absolute voltage	$V_{B1,2,3}$	$V_{S1,2,3}+8$	$V_{S1,2,3}+15$	$V_{S1,2,3}+20$	V
High side floating offset relative voltage	$V_{S1,2,3}$	GND-5	-	200	V
High side output voltage	$V_{HO1,2,3}$	$V_{S1,2,3}$	$V_{S1,2,3}+15$	$V_{B1,2,3}$	V
Power supply	V_{CC}	8	15	20	V
Low side output voltage	$V_{LO1,2,3}$	0	15	V_{CC}	V
Input voltage ($HIN1,2,3 / LIN1,2,3$)	V_{IN}	0	-	5	V

Note: T_A means the environmental temperature of the circuit;

6.8.4 Electrical Characteristic parameter table

(TA=25°C, VCC=VBS_{1,2,3}=15V, VS_{1,2,3}=GND, GND as a reference point for all pins, Unless otherwise indicated)

Parameter	Symbol	Condition	Min	Typical	Max	Unit
Power supply current parameters						
VCC static current	I _{CCQ}	V _{IN} =0V	250	300	400	uA
VBS static current	I _{BSQ}	V _{HIN} =0V	30	54	70	uA
VCC dynamic current	I _{CCD}	f _{LIN1,2,3} =20kHz	300	560	750	uA
VBS dynamic current	I _{BSD}	f _{HIN1,2,3} =20kHz	120	180	240	uA
VB floating power supply leakage current	I _{LK}	VB=225V	-	-	0.1	uA
Power supply voltage parameters						
VCC undervoltage high-level potential	V _{CCHY+}	-	5.5	6.8	7.0	V
VCC undervoltage low -level potential	V _{CCHY-}	-	5.0	6.2	6.5	V
VCC undervoltage hysteresis level	V _{CCHY}	-	-	0.6	-	V
VBS undervoltage high-level potential	V _{BSHY+}	-	5.5	6.8	7.0	V
VBS undervoltage low -level potential	V _{BSHY-}	-	5.0	6.2	6.5	V
VBS undervoltage hysteresis level	V _{BSHY}	-	-	0.6	-	V
VS static negative voltage	V _{SQN}	VBS=15V	-	-5.0	-	V
Input parameters						
Input high level current	I _{IN+}	V _{IN} =5V	30	50	70	uA
Input low level current	I _{IN-}	V _{IN} =0V	-	0	1	uA
Input high level potential	V _{IN+}	-	2.6	-	-	V
Input low level potential	V _{IN-}	-	-	-	0.8	V
Input hysteresis level	V _{INHY}	-	-	1.2	-	V
Output parameters						
High level shot-circuit pulse current	I _{OUT+}	V _{IN} =5V V _O =0V PWD≤10μs	0.8	1.1	1.4	A
Low level short-circuit pulse current	I _{OUT-}	V _{IN} =0V V _O =15V PWD≤10μs	1.5	2.0	2.5	A
High level output voltage	V _{OUT+}	I _{OUT} =-100mA	14.20	14.48	-	V
Low level output voltage	V _{OUT-}	I _{OUT} =+100mA	-	0.17	0.35	V
Time parameters						
Output rising edge transmission time	t _{ON}	No Load	140	220	300	ns
Output falling edge transmission time	t _{OFF}	No Load	140	220	300	ns
Output rising time	t _r	C _L =3.3nF	-	50	80	ns
Output falling time	t _f	C _L =3.3nF	-	23	40	ns
Dead time	DT	No Load	210	310	410	ns
High and low side match time	MT	-	-	-	50	ns

6.8.5 VS Negative Voltage Curve

The Negative Transient Safe Operating Area (NTSOA) is used to characterize the gate driver's ability to handle transient negative voltages. Negative pulses with amplitudes and pulse widths within the area above the blue line shown in the figure below will allow the gate driver to operate normally. Pulses with excessive amplitude (in the area below the blue line) may cause the gate driver to operate improperly or even be permanently damaged.

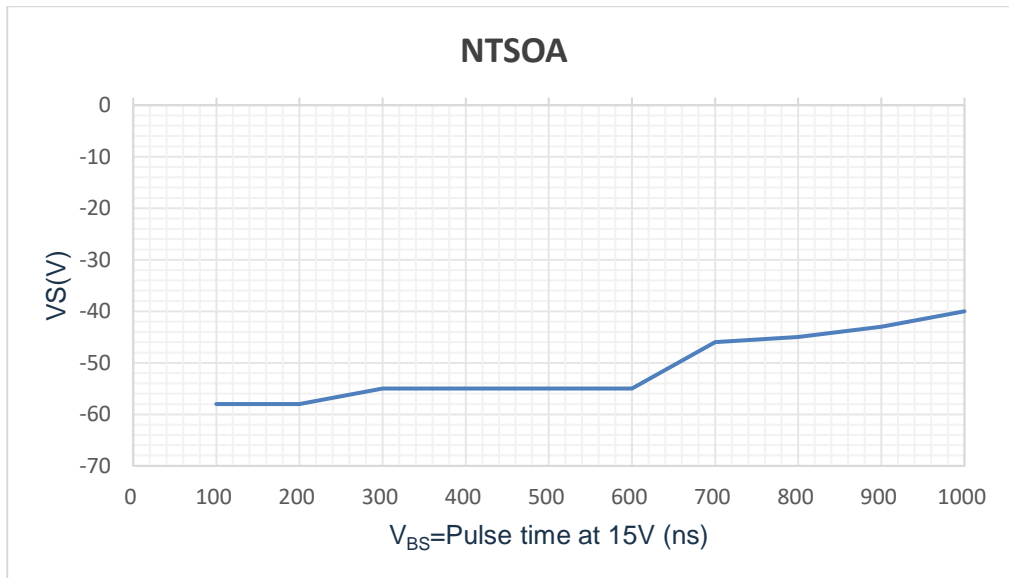

6.9 GATE DRIVER(3P3N) Electrical Characteristic (CMS32M5524)

6.9.1 Absolute Maximum Ratings

CMS32M5512 (Unless otherwise indicated, $T_A=25^{\circ}\text{C}$)

Parameter	Symbol	Range			Unit
		Min	Typical	max	
Power supply voltage	GVDD	8	12	16	V
Input frequency	Fin	-	-	100	KHz

CMS32M5524 (Unless otherwise indicated, $T_A=25^{\circ}\text{C}$) .

Parameter	Symbol	Range			Unit
		Min	Typical	Max	
Power supply voltage	GVDD	16	24	30	V
Input frequency	Fin	-	-	100	KHz

6.9.2 Electrical characteristic parameters

6.9.2.1 Driving NMOS power transistors

(Unless otherwise indicated, $V_{DD}=12\text{V}$, $T_A=25^{\circ}\text{C}$) .

Parameter	Symbol	Range			Unit
		Min	Typical	max	
Power supply voltage	GVDD	8	12	16	V
Input frequency	Fin	-	-	100	KHz

6.9.2.2 Driving PMOS power transistors

(Unless otherwise indicated, $V_{DD}=12\text{V}$, $T_A=25^{\circ}\text{C}$) .

Parameter	Condition	Min	Typical	Max	Unit
I_{inP*_IN} input current	$V_{P*_IN}=5\text{V}$	0.7	0.9	1.1	mA
V_{OH} output high level	NO Load	10.5	11	-	V
V_{OL} output low level	NO Load	-	-	1	
tPHH rise edge delay	VDD=12V, NO Load	-	75	150	ns
tPLL fall edge delay		-	75	150	
tr rise edge	VDD=12V, CL=1nF	-	100	300	
tf fall edge	VDD=12V, CL=1nF	-	100	300	

6.9.3 Time Parameter Test Description

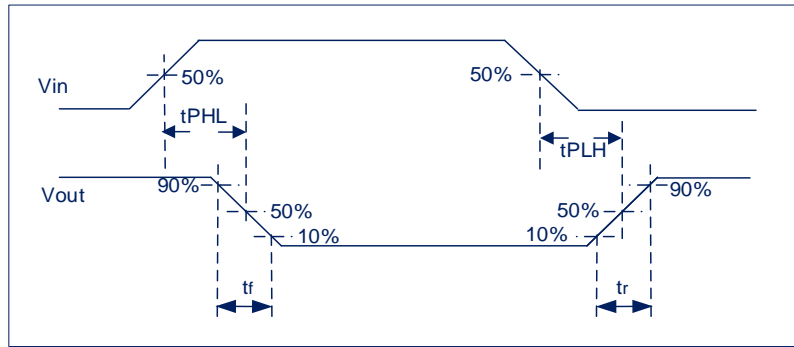
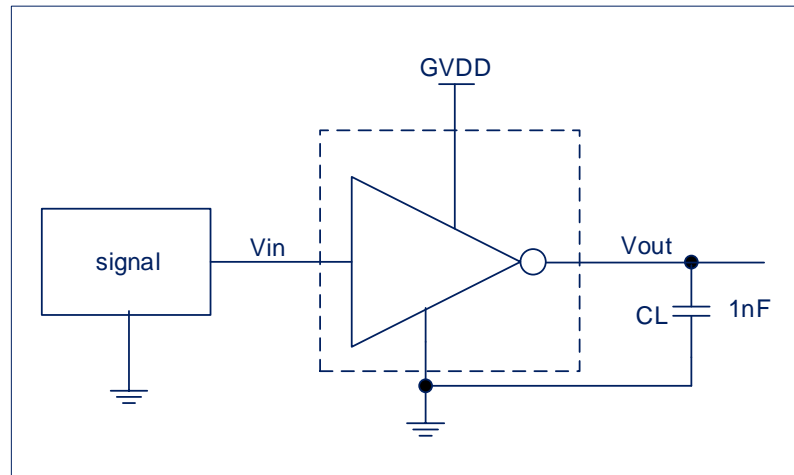
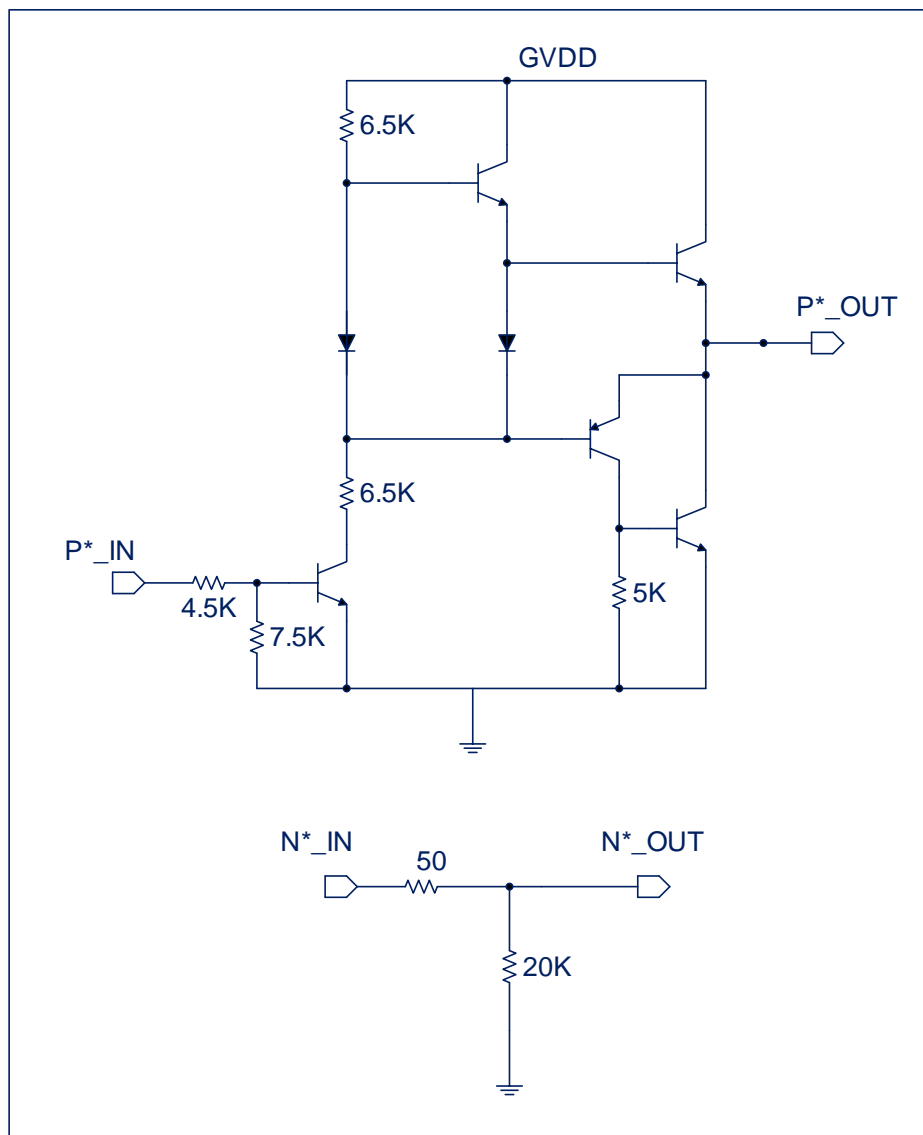

Diagram of time parameter test



Block diagram of test circuit

6.9.4 3P3N Pre-driver Internal Logic Block Diagram Characteristic



3P3N pre-driver internal logic block diagram

6.9.5 Logical Truth Table

NMOS Logical Truth Table

N*_IN	N*_OUT
Hanging	L
L	L
H	H

PMOS Logical Truth Table

P*_IN	P*_OUT
Hanging	H
L	H
H	L

Note: *Represents the numbers 1, 2, 3

6.10 GATE DRIVER(3P3N) Electrical Characteristic (CMS32M5526)

6.10.1 Internal Logic Block Diagram

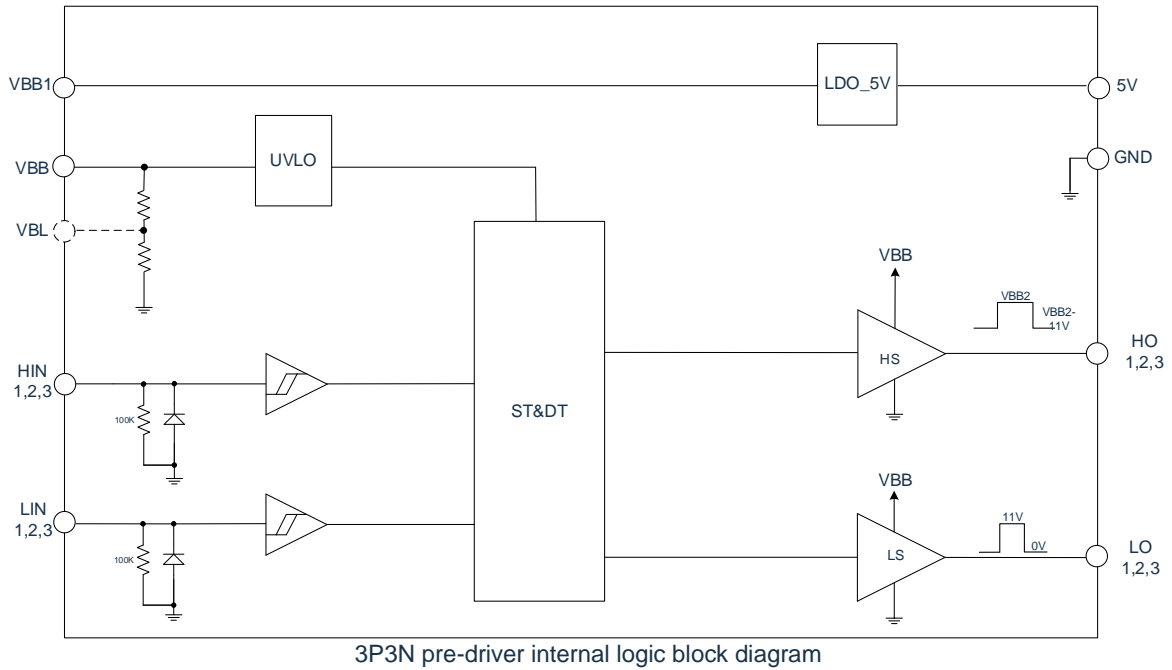

Logic Truth Table

HIN	LIN	UVLO/ST	HO	LO
0	0	0	OFF	OFF
0	1	0	OFF	ON
1	0	0	ON	OFF
1	1	1	OFF	OFF
Hanging	Hanging	0	OFF	OFF

Note:

- 1) 1: logic high level, 0: logic low level;
- 2) ON: $V_{HO}=V_{BB}-11V$, $V_{LO}=11V$ OFF: $V_{HO}=V_{BB}$, $V_{LO}=0V$

6.10.2 Absolute Maximum Ratings

($T_A=25^{\circ}\text{C}$, Unless otherwise indicated, GND as a reference point for all pins)

Parameter	Symbol	Min	Max	Unit
5V power supply voltage	V_{BB1}	-0.3	40	V
Drive power supply voltage	V_{BB}	-0.3	40	V
LDO output voltage	V_{5V}	-0.3	6	V
LDO output current	I_{5V}	0	100	mA
Input voltage (HIN1,2,3/LIN1,2,3)	V_{IN}	$V_{BB2}-11-0.3$	V_{BB2}	V
Output voltage of upper half bridge	V_{HO}	-0.3	12	V
Output voltage of lower half bridge	V_{LO}	-0.3	6	V
Environmental thermal resistance ^(note 1)	θ_{JA}	-	60	$^{\circ}\text{C}/\text{W}$
Junction temperature	T_J	-	150	$^{\circ}\text{C}$
Storage temperature	T_S	-55	150	$^{\circ}\text{C}$
Welding temperature of pins (duration 10s)	T_L	-	260	$^{\circ}\text{C}$
ESD ^(note 2)	V_{ESD}	-	2000	V

Note:

- 1) T_A is the environmental temperature, θ_{JA} is package thermal resistance, the highest junction temperature for the circuit is 150°C ;
- 2) Human model, 100pF capacitor is discharged through the 1.5K Ω resistor;
- 3) When the working conditions of circuit exceed the range specified by the absolute maximum ratings, it is likely to cause immediate damage to the circuit.

6.10.3 Recommended working conditions

($T_A=25^{\circ}\text{C}$, Unless otherwise indicated, GND as a reference point for all pins)

Parameter	Symbol	Min	Typical	Max	Unit
5V power supply voltage	V_{BB1}	7	24	36	V
Drive power supply voltage	V_{BB}	9	24	36	V
Input voltage (HIN/LIN)	V_{IN}	0	-	5	V

Note: T_A means the environmental temperature of the circuit;

6.10.4 Electrical Characteristic parameter table

($T_A=25^{\circ}\text{C}$, $V_{BB1}=V_{BB2}=V_{BB}=24\text{V}$, $\text{GND}=0$, the ground capacitance of VBB and VREG5 is 1uF. All pins use GND as the reference point unless otherwise specified)

Parameter	Symbol	Condition	Min	Typical	Max	Unit
Power supply current parameters						
V_{BB} static current	I_{VBBQ}	$V_{HIN}=V_{LIN}=0$	-	400	-	μA
V_{BB} dynamic current	I_{VBBD}	$f_{LIN}=16\text{kHz}$	-	1.4	-	mA
Power supply voltage parameters						
V_{BB} undervoltage high-level potential	V_{BBHY+}	-	-	8.5	-	V
V_{BB} undervoltage low-level potential	V_{BBHY-}	-	-	8.5	-	V
V_{BB} undervoltage hysteresis level	V_{BBHY}	-	-	0.5	-	V
Input parameters						
Input high level current	I_{IN+}	V_{HIN} 或 $V_{LIN}=5\text{V}$	-	50	-	μA
Input low level current	I_{IN-}	V_{HIN} 或 $V_{LIN}=0$	-	0	1	μA
Input high level potential	V_{IN+}	-	2.5	-	-	V
Input low level potential	V_{IN-}	-	-	-	0.8	V
Input hysteresis level	$V_{INH Y}$	-	-	0.8	-	V
Voltage divider output parameter						
Voltage divider output voltage	V_{OUT}	$SE=OV/KEY=VBAT/EN=5\text{V}$	-	1.91	-	V
Voltage divider output ratio	K	$V_{OUT}/VBAT$	-	0.0863	-	
Output parameters						
HO output current	I_{HO+}	$V_{HIN}=0$, $V_{HO}=V_{BB}$, $PWD\leq 10\mu\text{s}$	-	300	-	mA
HO inhalation current	I_{HO-}	$V_{HIN}=5\text{V}$, $V_{HO}=V_{BB}-11\text{V}$, $PWD\leq 10\mu\text{s}$	-	60	-	mA
LO output current	I_{LO+}	$V_{LIN}=5\text{V}$, $V_{LO}=0$, $PWD\leq 10\mu\text{s}$	-	50	-	mA
LO inhalation current	I_{LO-}	$V_{LIN}=0$, $V_{LO}=11\text{V}$, $PWD\leq 10\mu\text{s}$	-	260	-	mA
HO output voltage	V_{HO}	-	$V_{BB}-11$	-	V_{BB}	V
LO output voltage	V_{LO}	$V_{LIN}=5\text{V}$	-	11	-	V
Time parameters						
Output rising edge transmission time	T_{ON}	NO Load	-	200	-	ns
Output falling edge transmission time	T_{OFF}	NO Load	-	200	-	ns
HO output rising time	T_{rise_H}	$C_L=1\text{nF}$	-	60	-	ns
HO output falling time	T_{fall_H}	$C_L=1\text{nF}$	-	170	-	ns
LO output rising time	T_{rise_L}	$C_L=1\text{nF}$	-	200	-	ns
LO output falling time	T_{fall_L}	$C_L=1\text{nF}$	-	55	-	ns
Dead time	DT	NO Load	-	300	-	ns
High and low side match time	MT	ΔT_{ON} & ΔT_{OFF}	-	-	50	ns
LDO parameter						
Range of output voltage	V_{5V}	$V_{BB1}=7\text{V}\sim 36\text{V}$	4.8	-	5.2	V
LDO output current	I_{5V}	$V_{BB1}=7\text{V}\sim 36\text{V}$	-	-	60	mA

Voltage regulation rate	ΔV_O	$I_{5V}=100\text{mA}$, $V_{BB1}=12\text{V}\sim 24\text{V}$	-	5	10	mV
Load regulation rate	ΔV_{OL}	$V_{BB1}=24\text{V}$, $I_{5V}=0\sim 60\text{mA}$	-	-	40	mV
Overload startup limit current	I_{limit}	-	-	15	-	mA

6.11 GATE DRIVER (3P3N) Electrical Characteristic (CMS32M5526C)

6.11.1 Internal Logic Block Diagram

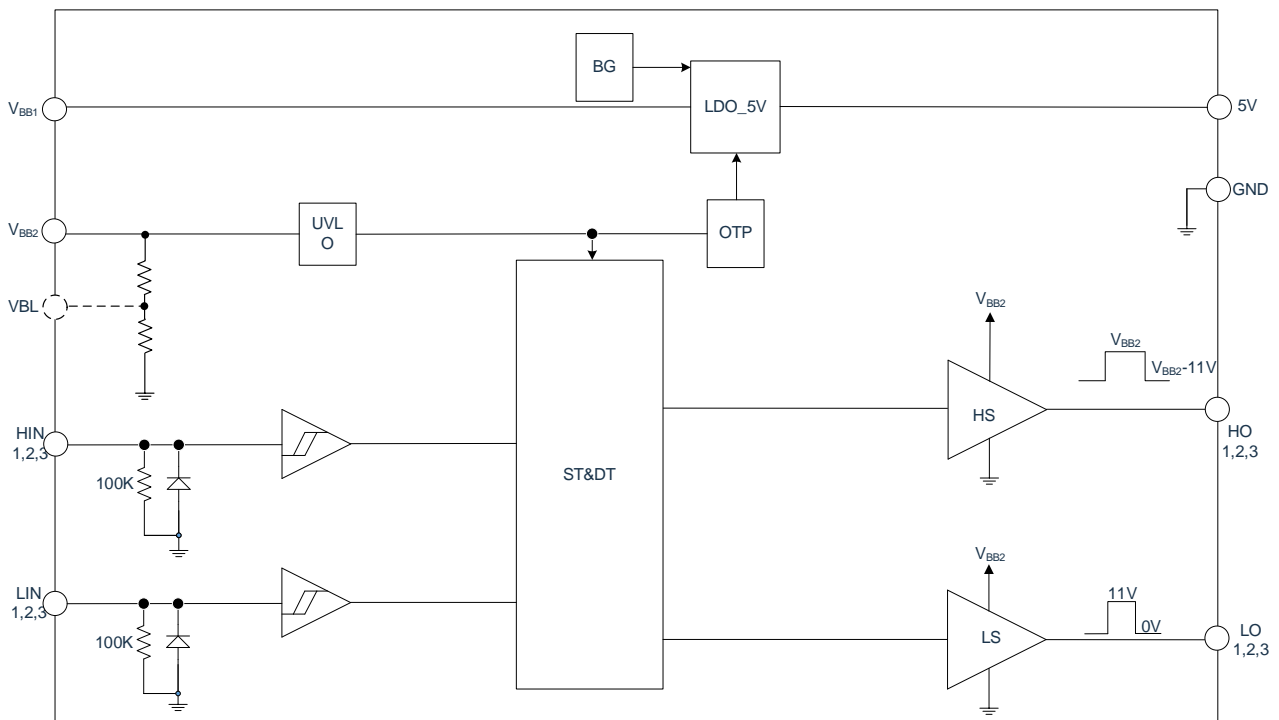

3P3N pre-driver internal logic block diagram

Logic Truth Table

HIN _{1,2,3}	LIN _{1,2,3}	HO _{1,2,3}	LO _{1,2,3}
0	0	OFF	OFF
0	1	OFF	ON
1	0	ON	OFF
1	1	OFF	OFF
Hanging	Hanging	OFF	OFF

Note:

- 1) 1: logic high level, 0: logic low level;
- 2) ON: $V_{HO1,2,3}=V_{BB2}-11V$, $V_{LO1,2,3}=11V$ OFF: $V_{HO1,2,3}=V_{BB2}$, $V_{LO1,2,3}=0V$

6.11.2 Absolute Maximum Ratings

($T_A=25^{\circ}\text{C}$ Unless otherwise indicated, GND as a reference point for all pins)

Parameter	Symbol	Max	Min	Unit
VREG5 power supply voltage	V_{BB1}	-0.3	40	V
Drive power supply voltage	V_{BB2}	-0.3	40	V
LDO output voltage	V_{5V}	-0.3	6	V
LDO output current	I_{LOAD}	0	30	mA
High side output voltage	$V_{HO1,2,3}$	$V_{BB2}-12-0.3$	V_{BB2}	V
Low side output voltage	$V_{LO1,2,3}$	-0.3	12	V
Logic input voltage	V_{IN}	-0.3	6	V
Environmental thermal resistance ^(note 1)	θ_{JA}	-	60	$^{\circ}\text{C}/\text{W}$
Junction temperature	T_J	-	150	$^{\circ}\text{C}$
Storage temperature	T_S	-55	150	$^{\circ}\text{C}$
Welding temperature of pins (duration 10s)	T_L	-	260	$^{\circ}\text{C}$
ESD_HBM ^(note 2)	V_{ESD1}	-	4000	V
ESD_CDM	V_{ESD2}	-	1000	V

Note:

- 1) T_A is the environmental temperature, θ_{JA} is package thermal resistance, the highest junction temperature for the circuit is 150°C
- 2) Human model, 100pF capacitor is discharged through the 1.5k Ω resistor;
- 3) When the working conditions of circuit exceed the range specified by the absolute maximum ratings, it is likely to cause immediate damage to the circuit.

6.11.3 Recommended working conditions

($T_A=25^{\circ}\text{C}$, Unless otherwise indicated, GND as a reference point for all pins)

Parameter	Symbol	Min	Typical	Max	Unit
VREG5 power supply voltage	V_{BB1}	5	24	36	V
Drive power supply voltage	V_{BB2}	5	24	36	V
Input voltage (HIN1,2,3/LIN1,2,3)	V_{IN}	0	-	5	V

Note: T_A represents the ambient temperature at which the circuit works.

6.11.4 Electrical Characteristic parameter table

($T_A=25^{\circ}\text{C}$, $V_{BB1}=V_{BB2}=V_{BB}=24\text{V}$, $\text{GND}=0$, the ground capacitance of V_{BB} and V_{REG5} is $1\mu\text{F}$. All pins use GND as the reference point unless otherwise specified)

Parameter	Symbol	Condition	Min	Typical	Max	Unit
Power supply current parameters						
V_{BB} static current	I_{BBQ}	$V_{\text{HIN}1,2,3}=V_{\text{LIN}1,2,3}=0$	-	790	-	μA
V_{BB} dynamic current	I_{BBD}	$f_{\text{VIN}}=20\text{kHz}$	-	1.6	-	mA
Power supply voltage parameters						
V_{BB} undervoltage high-level potential	$V_{\text{BBHY}+}$	-	-	4.3	-	V
V_{BB} undervoltage low-level potential	$V_{\text{BBHY}-}$	-	-	3.9	-	V
V_{BB} undervoltage hysteresis level	V_{BBHY}	-	-	0.4	-	V
Input parameters						
Input high level current	$I_{\text{IN}+}$	$V_{\text{HIN}1,2,3}$ or $V_{\text{LIN}1,2,3}=5\text{V}$	-	55	-	μA
Input low level current	$I_{\text{IN}-}$	$V_{\text{HIN}1,2,3}$ or $V_{\text{LIN}1,2,3}=0$	-	0	1	μA
Input high level potential	$V_{\text{IN}+}$	-	2.6	-	-	V
Input low level potential	$V_{\text{IN}-}$	-	-	-	1.5	V
Input hysteresis level	$V_{\text{INH Y}}$	-	-	0.9	-	V
Voltage divider output parameter						
Voltage divider output voltage	V_{OUT}	$\text{SE}=\text{OV}/\text{KEY}=\text{VBAT}/\text{EN}=5\text{V}$	-	1.91	-	V
Voltage divider output ratio	K	$V_{\text{OUT}}/\text{VBAT}$	-	0.0863	-	
Protection function						
Overheat shut-off protection	T_{shut}	-	-	170	-	$^{\circ}\text{C}$
Temperature lag	T_{hys}	-	-	22	-	$^{\circ}\text{C}$
Output parameters						
HO output current	$I_{\text{HO}+}$	$V_{\text{HIN}1,2,3}=0$, $V_{\text{HO}1,2,3}=V_{\text{BB}}$, $\text{PWD}\leq 10\mu\text{s}$	170	200	244	mA
HO inhalation current	$I_{\text{HO}-}$	$V_{\text{HIN}1,2,3}=5\text{V}$, $V_{\text{HO}1,2,3}=V_{\text{BB}}-11\text{V}$, $\text{PWD}\leq 10\mu\text{s}$	55	62	76	mA
LO output current	$I_{\text{LO}+}$	$V_{\text{LIN}1,2,3}=5\text{V}$, $V_{\text{LO}}=0$, $\text{PWD}\leq 10\mu\text{s}$	30	36	42	mA
LO inhalation current	$I_{\text{LO}-}$	$V_{\text{LIN}1,2,3}=0$, $V_{\text{LO}1,2,3}=11\text{V}$, $\text{PWD}\leq 10\mu\text{s}$	228	276	328	mA
HO output voltage	V_{HO}	$V_{\text{BB}}\geq 12\text{V}$, $V_{\text{HIN}}=5\text{V}$	-	$V_{\text{BB}}-11.2$	-	V
		$V_{\text{BB}}< 12\text{V}$, $V_{\text{HIN}}=5\text{V}$	-	1	1.5	V
		$V_{\text{HIN}}=0\text{V}$	-	V_{BB}	-	V
LO output voltage	V_{LO}	$V_{\text{BB}}\geq 12\text{V}$, $V_{\text{LIN}}=5\text{V}$	-	11.2	-	V
		$V_{\text{BB}}< 12\text{V}$, $V_{\text{LIN}}=5\text{V}$	-	$V_{\text{BB}}-1$	$V_{\text{BB}}-1.5$	V
		$V_{\text{LIN}1,2,3}=0\text{V}$	-	0	-	V
Time parameters						
Output rising edge transmission time	T_{ON}	No Load	-	145	-	ns
Output falling edge transmission time	T_{OFF}	No Load	-	120	-	ns
HO output rising time	T_{rise_H}	$C_L=1\text{nF}$	-	78	-	ns

HO output falling time	T_{fall_H}	$C_L=1nF$	-	205	-	ns
LO output rising time	T_{rise_L}	$C_L=1nF$	-	410	-	ns
LO output falling time	T_{fall_L}	$C_L=1nF$	-	58	-	ns
Dead time	DT	-	-	150	250	ns
High and low side match time	MT	ΔT_{ON} & ΔT_{OFF}	-	-	50	ns
LDO parameter						
Range of output voltage	V_{5V}	$V_{BB1}=7V\sim 36V$, no load	4.90	5.00	5.05	V
Range of output voltage	V_{5V}	$V_{BB1}=7V\sim 36V$, load 30mA	4.85	4.97	5.00	V
LDO output current	I_{load}	$V_{BB1}=7V\sim 36V$	-	-	30	mA
Voltage regulation rate	ΔV_O	$I_{load}=30mA$, $V_{BB1}=12V\sim 24V$	-50	-	50	mV
Load regulation rate	ΔV_{OL}	$V_{BB1}=24V$, $I_{load}=0\sim 30mA$	-70	-	70	mV
Current limiting value	LIMIT	-	80	96	-	mA

6.12 EMC Characteristic

6.12.1 EFT Electrical Characteristics

Symbol	Parameter	Condition	level
V _{EFTB}	Fast transient voltage burst limits to be applied through 0.1uF(capacitance) on VDD and VSS pins to induce a functional disturbance	T _A = + 25 °C, HSI=64MHz, conforms to IEC 61000-4-4	4B

Note: EFT performance is closely related to system design, including power structure, circuit design, the layout, chip configuration and program structure. EFT parameters in above table are internal testing result in CMS, not suitable for all application environments. These parameters are for reference only. System design has influence upon EFT performance. For some special application which needs high EFT performance, please try to avoid interference sources affecting the system when designing. It is suggested to analyze interfering path and optimize design in order to achieve the best anti-interference performance.

6.12.2 ESD Electrical Characteristics

Symbol	Parameter	Condition	level
V _{ESD}	Electrostatic discharge (human body model HBM)	T _A = + 25 °C, JEDEC EIA/JESD22- A114	3B
	Electrostatic discharge (Machine discharge model MM)	T _A = + 25 °C, JEDEC EIA/JESD22- A115	C

Remark: It is guaranteed by the design and not tested in mass production.

6.12.3 Latch-Up Electrical Characteristics

Symbol	Parameter	Condition	Type
LU	Static latch-up class	JEDEC STANDARD NO.78D NOVEMBER 2011	Class I (T _A = +25°C)

Remark: It is guaranteed by the design and not tested in mass production.

7. Package Dimensions

7.1 SOP16

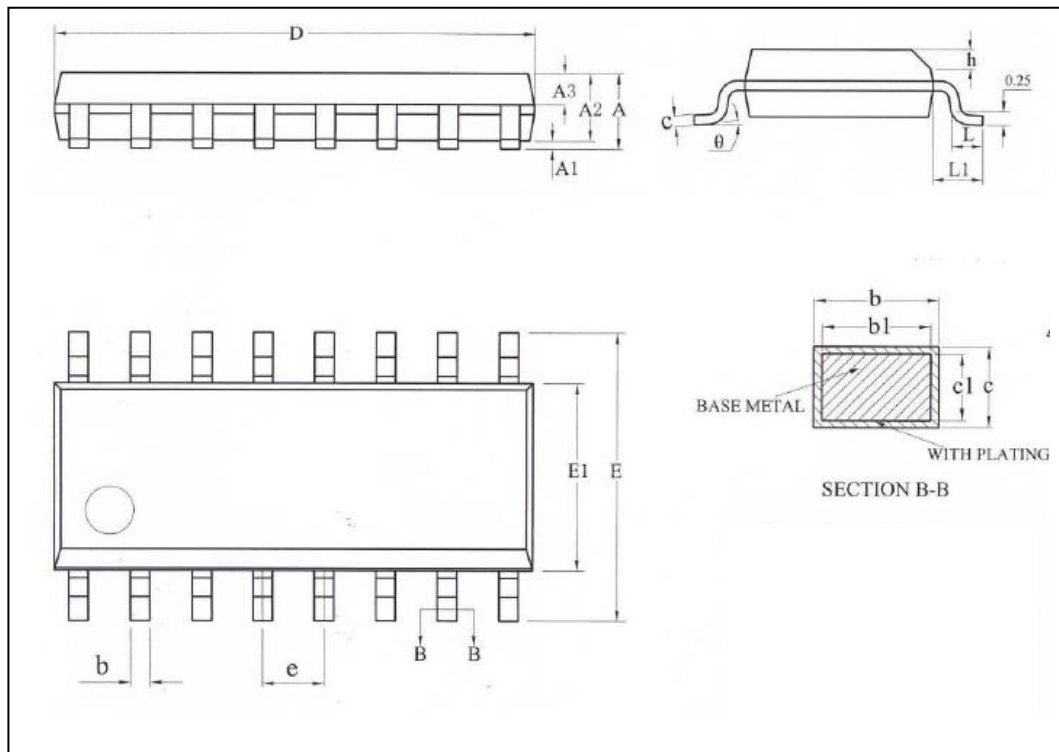

Symbol	Millimeter		
	Min	Nom	Max
A	-	-	1.75
A1	0.10	-	0.225
A2	1.30	1.40	1.50
A3	0.60	0.65	0.70
b	0.39	-	0.47
b1	0.38	0.41	0.44
c	0.20	-	0.24
c1	0.19	0.20	0.21
D	9.80	9.90	10.00
E	5.80	6.00	6.20
E1	3.80	3.90	4.00
e	1.27BSC		
h	0.25	-	0.50
L	0.50	-	0.80
L1	1.05REF		
θ	0	-	8°

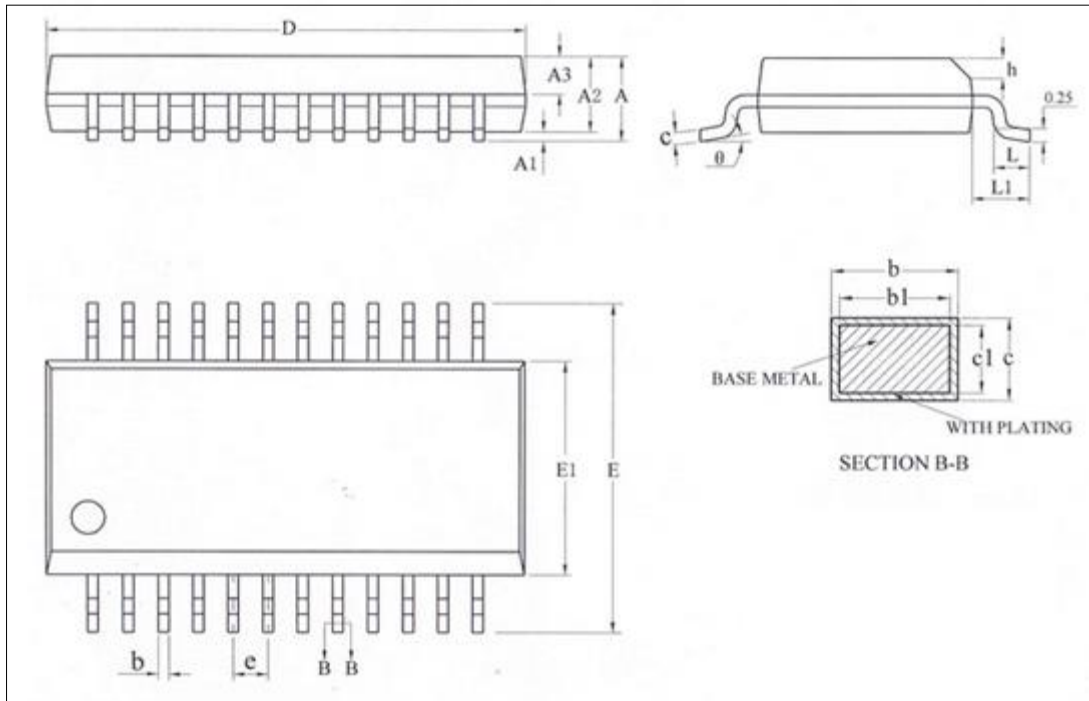
7.2 SSOP24

Symbol	Millimeter		
	Min	Nom	Max
A	-	-	1.75
A1	0.10	0.15	0.25
A2	1.30	1.40	1.50
A3	0.60	0.65	0.70
b	0.23	-	0.31
b1	0.22	0.25	0.28
c	0.20	-	0.24
c1	0.19	0.20	0.21
D	8.55	8.65	8.75
E	5.80	6.00	6.20
E1	3.80	3.90	4.00
e	0.635BSC		
h	0.30	-	0.50
L	0.50	-	0.80
L1	1.05REF		
θ	0	-	8°

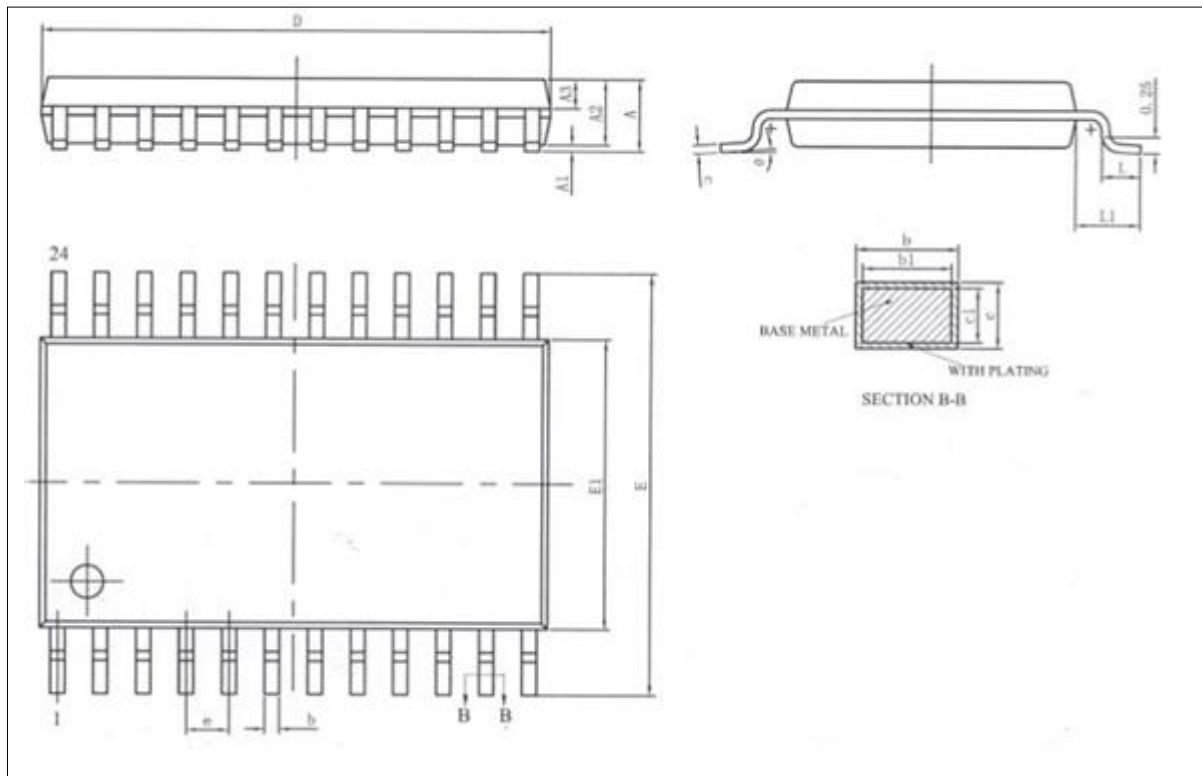
7.3 TSSOP24

Symbol	Millimeter		
	Min	Nom	Max
A	-	-	1.2
A1	0.05	-	0.15
A2	0.80	1.00	1.05
A3	0.39	0.44	0.49
b	0.20	-	0.29
b1	0.19	0.22	0.25
c	0.13	-	0.18
c1	0.12	0.13	0.14
D	7.70	7.80	7.90
E	6.20	6.40	6.60
E1	4.30	4.40	4.50
e	0.65BSC		
L	0.45	0.60	0.75
L1	1.00BSC		
θ	0°	-	8°

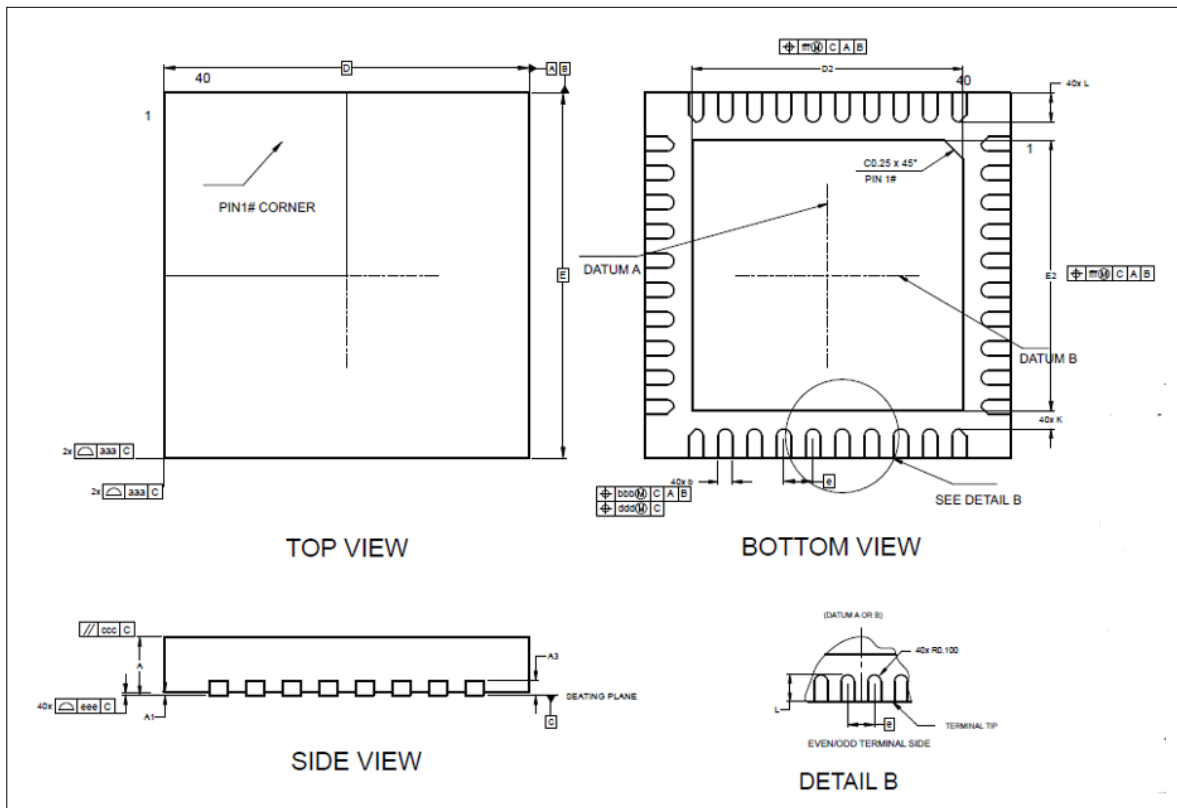
7.4 QFN40 (0505X0.75-0.40)

Symbol	Millimeter		
	Min	Nom	Max
A	0.70	0.75	0.80
	0.80	0.85	0.90
	0.85	0.90	0.95
A1	0	0.02	0.05
A3	-	0.20REF	-
b	0.15	0.20	0.25
D	5.0BSC		
E	5.0BSC		
D2	3.60	3.70	3.80
E2	3.60	3.70	3.80
e	0.40BSC		
L	0.35	0.40	0.45
K	0.20	-	-
aaa	0.10		
bbb	0.07		
ccc	0.10		
ddd	0.05		
eee	0.08		
fff	0.10		

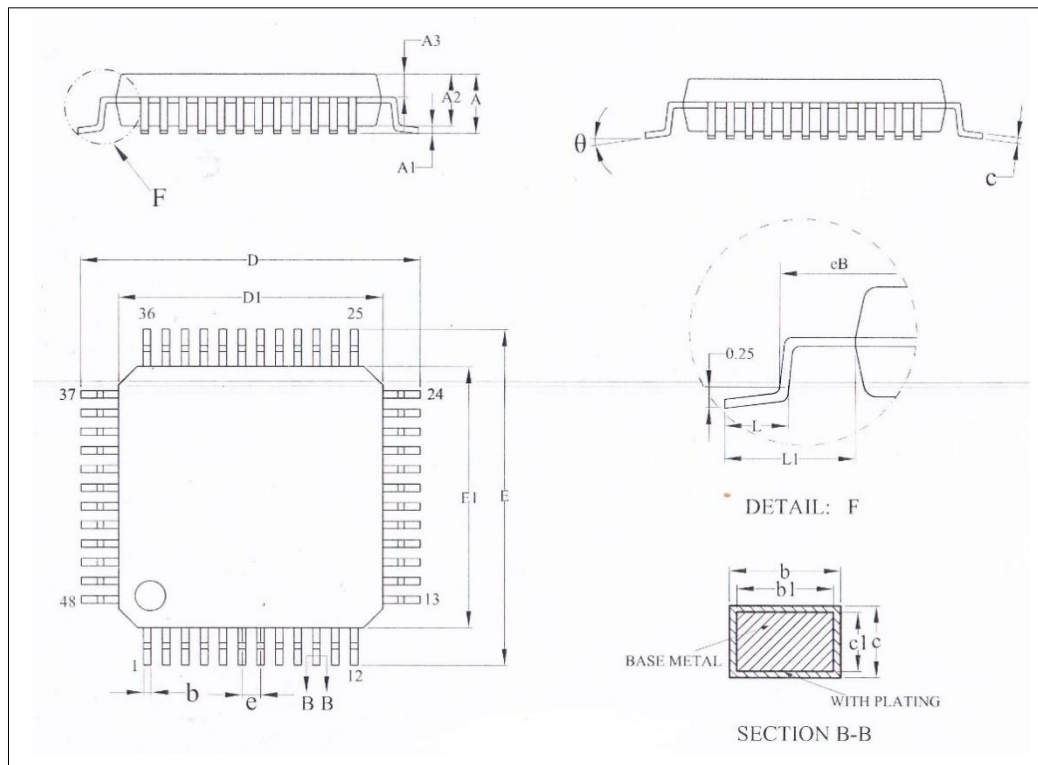
7.5 LQFP48 (0707X1.4-0.50)

Symbol	Millimeter		
	Min	Nom	Max
A	-	-	1.60
A1	0.05	-	0.15
A2	1.35	1.40	1.45
A3	0.59	0.64	0.69
b	0.18	-	0.26
b1	0.17	0.20	0.23
c	0.13	-	0.17
c1	0.12	0.13	0.14
D	8.80	9.00	9.20
D1	6.90	7.00	7.10
E	8.80	9.00	9.20
E1	6.90	7.00	7.10
eB	8.10	-	8.25
e	0.50BSC		
L	0.45	-	0.75
L1	1.00REF		
θ	0°	-	7°

8. Ordering Information

Product model	Kernel	Main frequency (MHZ)	Program FLASH (KB)	Data FLASH (KB)	SRAM(KB)	Built-in driver	Built-in LDO	Hardware multiplier	Hardware divider	GPIO	12-Bit ADC0	12-Bit ADC1	Built-in operational amplifier	Built-in PGA	Built-in comparator	EPWM	CCP	Timer	UART	I2C	SPI	Temperature Sensor	CRC	WDT	WWDT	PACKAGE
CMS32M5510S024	M0	64	32	1	8	-	0	1	1	22	22	22	2	2	2	6	2	2	2	1	1	0	1	1	1	SSOP24
CMS32M5512Q040	M0	64	32	1	8	3P3N (8-16V)	0	1	1	22	22	22	2	2	2	6	2	2	2	1	1	0	1	1	1	QFN40
CMS32M5524S016	M0	64	32	1	8	3P3N (16-30V)	0	1	1	7	7	7	1	2	1	6	2	2	1	1	0	0	1	1	1	SOP16
CMS32M5524S024	M0	64	32	1	8	3P3N (16-30V)	0	1	1	14	14	14	2	2	1	6	2	2	2	1	1	0	1	1	1	SSOP24
CMS32M5526TS024	M0	64	32	1	8	3P3N (9-36V)	1	1	1	13	13	13	2	1	1	6	2	2	2	1	1	0	1	1	1	TSSOP24
CMS32M5526S024	M0	64	32	1	8	3P3N (9-36V)	1	1	1	13	13	13	2	1	1	6	2	2	2	1	1	0	1	1	1	SSOP24
CMS32M5526CS024	M0	64	32	1	8	3P3N (5-36V)	1	1	1	13	13	13	2	1	1	6	2	2	2	1	1	0	1	1	1	SSOP24
CMS32M5526Q040	M0	64	32	1	8	3P3N (9-36V)	1	1	1	23	23	23	2	2	2	6	2	2	2	1	1	0	1	1	1	QFN40
CMS32M5533Q040	M0	64	32	1	8	6N (5.5-18V)	0	1	1	24	24	24	2	2	2	6	2	2	2	1	1	0	1	1	1	QFN40
CMS32M5533L048	M0	64	32	1	8	6N (5.5-18V)	0	1	1	24	24	24	2	2	2	6	2	2	2	1	1	0	1	1	1	LQFP48
CMS32M5536L048	M0	64	32	1	8	6N (8-20V)	0	1	1	24	24	24	2	2	2	6	2	2	2	1	1	0	1	1	1	LQFP48

9. Revision History

Revision	Date	Modify content
V1.00	Apr 2019	Initial version
V1.01	Apr 2020	Modify the description of memory space
V1.02	May 2020	System overview chapter adds system structure block diagram
V1.03	Sep 2020	Add SOP16 pin map and related information of CMS32M5524
V1.04	Oct 2020	Modify the static/dynamic parameters in Chapter 6.8
V1.05	Nov 2020	Add related information of CMS5510S016/CMS5512S016/CMS5336L048
V1.06	Dec 2020	Add related information of CMS32M5533L032
V1.07	Jul 2021	1) Add related information of CMS32M5524TS024/CMS32M5526TS024 2) Remove related information of CMS32M5332/ CMS32M5333L/ CMS32M5510sop16/ CMS32M5512 Sop16
V1.08	Sep 2021	1) Add related information of CMS32M5526S024/CMS32M5526Q040 2) Add related information of CMS32M5512
V1.09	Feb 2022	Modify the parameters in Chapter 6.7
V1.10	Apr 2022	1) 3.1 Pin Description, 3.2 Pin functions Description, 3.4 Pin Function List: Adjust SWD pin description and remarks (5) 2) 7.3 TSSOP24: Delete the chip picture
V1.11	Jun 2022	1) Modify the system block diagram of CMS32M5512 in chapter 2.3.2 2) 3.1.3 CMS32M5512(QFN40), 3.1.8 CMS32M5526(QFN40), 3.1.9 CMS32M5533(QFN40), 3.1.10 CMS32M5533(LQFP48), 3.1.11 CMS32M5536(LQFP48), 3.2 Pin Function Description 3.4 Pin Function List: Delete the CCP0A function of the P30
V1.12	Jul 2022	1.2 Product Comparison: add maximum voltage parameters
V1.13	Aug 2022	Corrected the QFN pin map format: 3.1.3 CMS32M5512(QFN40), 3.1.8 CMS32M5526(QFN40), 3.1.9 CMS32M5533 (QFN40)
V1.14	Oct 2022	3.1.2 CMS32M5510(LQFP32), 3.2.1 CMS32M5510/12/24/26/26C Function Description, 7.4 LQFP32: Added CMS32M5510(LQFP32)
V1.1.5	Feb 2023	1) Add related information of CMS32M5526C(SSOP24) in Chapter 2.1/ 2.3.4/ 3.1.7/ 3.2.1/ 6.8.4/6.10.4/0/8 2) Correct QFN40 package diagram data 3) SWD emulation burn port in change position (keep a set)
V1.1.6	Apr 2023	Updated 7.4 Package dimensions
V1.1.7	May 2023	Modified section 4.9.4
V1.1.8	Dec 2023	1) Modified the description of FLASH electrical parameters in 6.4 2) Added CMS32M5533E(QFN40, LQFP48) model information (the modified section includes: 1.2/3.1.8/3.1.9/3.2.2/6.7) 3) Add chapters: 6.6.1/6.6.4/6.8.1/6.8.5 4) Delete the CMS32M5510 package LQFP32 chip information 5) Updated 6.12 EMC Characteristic
V1.1.9	Jan 2024	1) Corrected CMS32M5526(QFN40) pin position 2) Corrected the cover page
V1.2.0	Jan 2024	Corrected some errors in section 3.4
V1.2.1	Apr 2024	1) Delete the stop mode in 1.1 2) Delete the stop mode in 2.1 3) Delete the stop mode in 3.3 4) Delete the stop mode in 4.5.1 5) Delete Stop mode current in 6.2
	May 2024	1) Modified sections 6.8.2, 6.8.3, 6.8.4, 6.10.2, 6.10.3, 6.10.4, 6.11.2, 6.11.3, and 6.11.4 2) Modify the parameters in 6.3.3 3) Remarks are added in sections 6.5.2, 6.5.3, 6.5.4, 6.5.5, 6.5.6, 6.12.2, 6.12.3 4) Changed the built-in driver supply voltage of CMS32M5526CS024 from 6.5~36V to 5~36V